

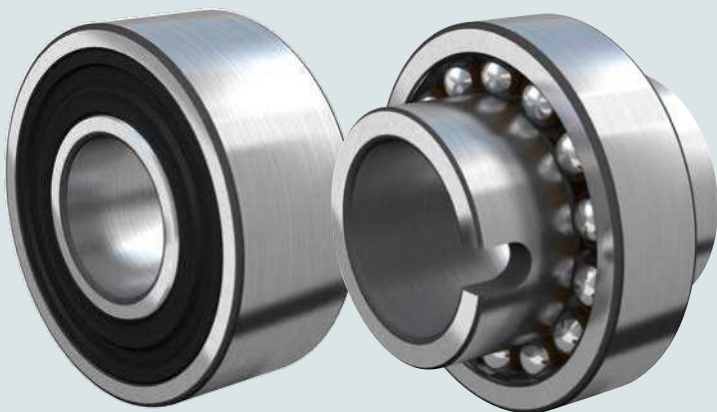

4

Self-aligning ball bearings



4 Self-aligning ball bearings



Designs and variants	439		
Sealed bearings	439		
Greases for capped bearings	440		
Grease life for capped bearings	440		
Large self-aligning ball bearings	440		
Bearings with an extended inner ring	440		
Cages	442		
Bearing data	443		
(Dimension standards, tolerances, internal clearance, permissible misalignment)			
Loads	445		
(Minimum load, axial load carrying capacity, equivalent dynamic bearing load, equivalent static bearing load)			
Temperature limits	445		
Permissible speed	446		
Design considerations	446		
Ball protrusion	446		
Bearings on sleeves	446		
Bearings with an extended inner ring	446		
Appropriate bearing housings	447		
Mounting	447		
Mounting bearings with a cylindrical bore	447		
Mounting bearings with a tapered bore	447		
Designation system	449		
Product tables			
4.1 Self-aligning ball bearings	450		
4.2 Self-aligning ball bearings on an adapter sleeve ..	458		
4.3 Self-aligning ball bearings with an extended inner ring	462		
		Other self-aligning ball bearings	
		Bearings with Solid Oil	1023

4 Self-aligning ball bearings



More information

General bearing knowledge	17
Bearing selection process	59
Lubrication	109
Bearing interfaces	139
Seat tolerances for standard conditions	148
Selecting internal clearance	182
Sealing, mounting and dismounting	193

Mounting instructions for individual bearings → skf.com/mount

SKF Drive-up Method
→ skf.com/drive-up

SKF bearing maintenance handbook ISBN 978-91-978966-4-1

Self-aligning ball bearings have two rows of balls, a common sphered raceway in the outer ring and two deep uninterrupted raceway grooves in the inner ring. They are available open or sealed. The bearings are insensitive to angular misalignment of the shaft relative to the housing (**fig. 1**), which can be caused, for example, by shaft deflection.

Bearing features

- **Accommodate static and dynamic misalignment**
The bearings are self-aligning like spherical roller bearings or CARB bearings.
- **Excellent high-speed performance**
Self-aligning ball bearings generate less friction than any other type of rolling bearing, which enables them to run cooler even at high speeds.
- **Minimum maintenance**
Because of low heat generation, the bearing temperature is lower, leading to extended bearing life and maintenance intervals.

- **Low friction**
Very loose conformity between balls and outer ring keeps friction and frictional heat at low levels.
- **Excellent light load performance**
Self-aligning ball bearings have low minimum load requirements.
- **Low noise**
Self-aligning ball bearings can reduce noise and vibration levels, for example, in fans.

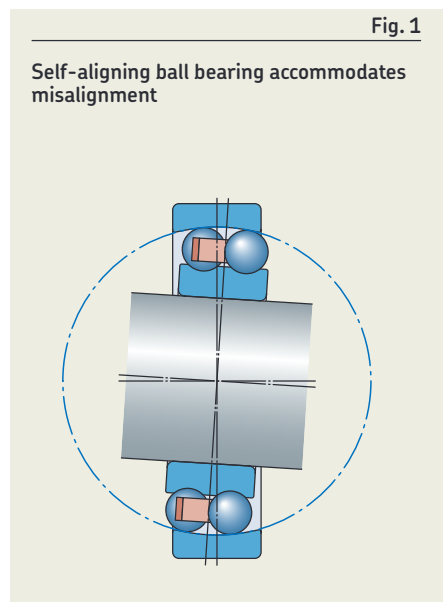

Designs and variants

SKF standard assortment

SKF self-aligning ball bearing variants are:

- open (fig. 2)
 - with cylindrical bore
 - with tapered bore, e.g. for use with adapter sleeves (fig. 3)
 - with extended inner ring (fig. 4)
- sealed (fig. 5)
 - with cylindrical bore
 - with tapered bore, e.g. for use with adapter sleeves

Sealed bearings

Sealed bearings equipped with contact seals on both sides (fig. 6) are available:

- in the 22 and 23 series
- with bore diameter $10 \leq d \leq 70$ mm
- with seals made of sheet steel reinforced NBR (oil and wear-resistant, designation suffix -2RS1)

Permissible angular misalignment of sealed bearings is slightly reduced compared to open design bearings.

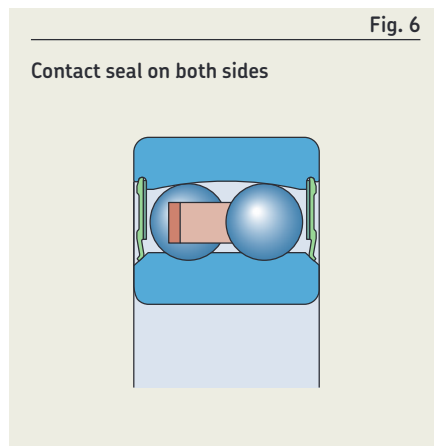
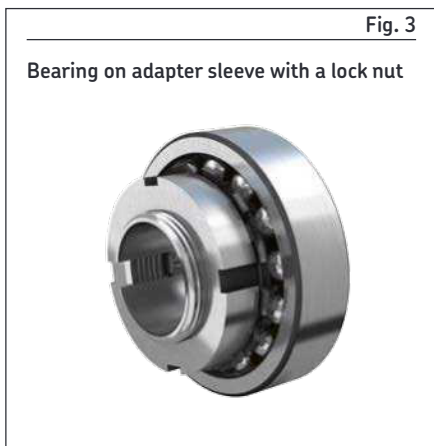
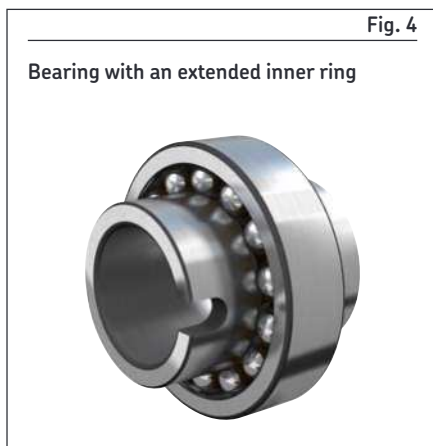
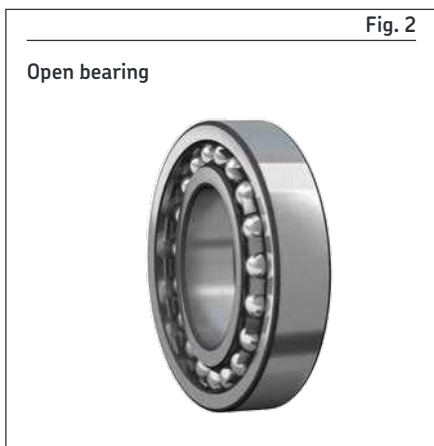

4 Self-aligning ball bearings

Greases for capped bearings

Bearings sealed on both sides are lubricated for the life of the bearing and are virtually maintenance-free. They are filled with one of the following standard greases, which have good corrosion-inhibiting properties (table 1):

- $D \leq 62 \rightarrow$ MT47 grease
- $D > 62 \rightarrow$ MT33 grease

Grease life for capped bearings

- is presented as L_{10} , i.e. the time period at the end of which 90% of the bearings are still reliably lubricated
- depends on the operating temperature and the nd_m value (diagram 1)

The grease life specified in diagram 1 is valid for the following combination of operating conditions:

- horizontal shaft
- inner ring rotation
- light load ($P \leq 0,05 C$)
- operating temperature within the green temperature zone of the grease (table 1)
- stationary machine
- low vibration levels

Where the operating conditions differ, the grease life obtained from the diagram should be adjusted:

- vertical shafts \rightarrow 50% of the obtained value
- heavier loads ($P > 0,05 C$) \rightarrow apply reduction factor (table 2)

When sealed bearings must operate under certain extreme conditions, such as very high speeds or high temperatures, grease may appear on the capping diameter. For bearing arrangements where this would be detrimental, appropriate actions should be taken. For additional information, contact the SKF application engineering service.

Large self-aligning ball bearings

- are available in the 130 and 139 series
- are equipped with an annular groove in the outer ring and (fig. 7):
 - three equally-spaced lubrication holes in the outer ring
 - six equally-spaced lubrication holes in the inner ring
- can be used in any application where low friction is preferred over high load carrying capacity (e.g. in the paper industry)

Bearings with an extended inner ring

- are (fig. 8) designed for less demanding applications that use commercial grade shafting
- have a special bore tolerance, class JS7 (table 3), that facilitates mounting and dismounting
- are located axially on the shaft by means of a slot at one end of the inner ring that engages a pin or shoulder screw (fig. 9) fitted to the shaft
 - This also prevents the shaft from spinning in the bearing bore.

Diagram 1

Grease life for standard capped self-aligning ball bearings where $P = 0,05 C$

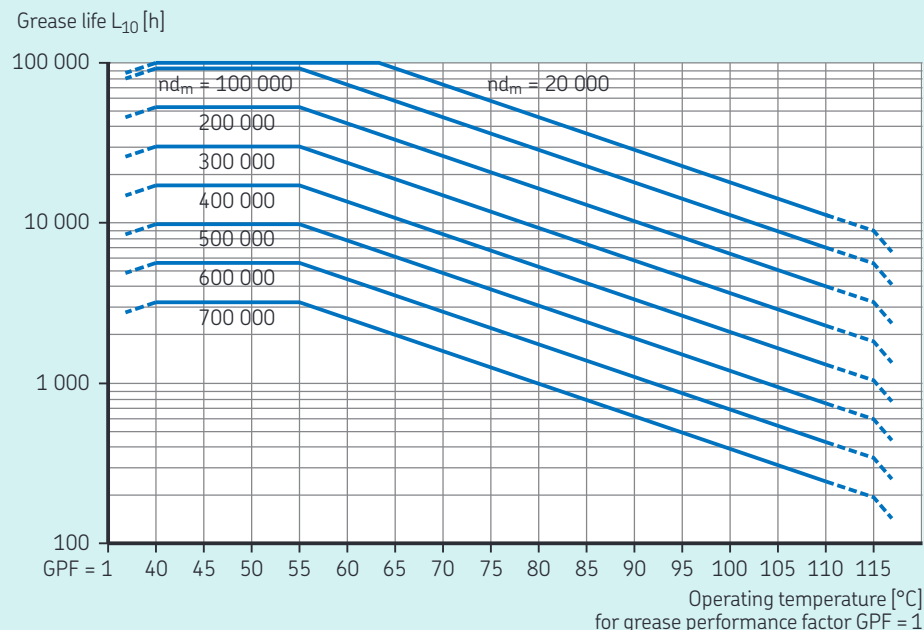

n = rotational speed [r/min]
 d_m = bearing mean diameter [mm]
 $= 0,5 (d + D)$

Table 1

Technical specifications of SKF standard greases for sealed self-aligning ball bearings

Bearing outside diameter [mm]	Grease	Temperature range ¹⁾							Thickener	Base oil type	NLGI grade	Base oil viscosity [mm ² /s]	
		-50	0	50	100	150	200	250				at 40 °C (105 °F)	at 100 °C (210 °F)
D ≤ 62	MT47								Lithium soap	Mineral	2	70	7,3
D > 62	MT33								Lithium soap	Mineral	3	100	10

¹⁾ Refer to the SKF traffic light concept (page 117).

Fig. 7

Annular groove and lubrication holes

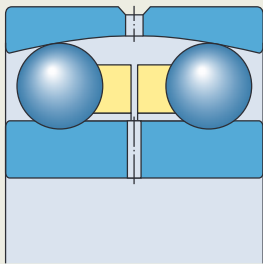

Table 2

Reduction factor for the grease life, depending on the load

Load P	Reduction factor
≤ 0,05 C	1
0,1 C	0,7
0,125 C	0,5
0,25 C	0,2

Table 3

Bore tolerance of self-aligning ball bearings with an extended inner ring

Bore diameter d	Tolerance class JS7	Deviation	
		U	L
mm		μm	
18	30	+10,5	-10,5
30	50	+12,5	-12,5
50	80	+15	-15

Fig. 8

Bearing with an extended inner ring

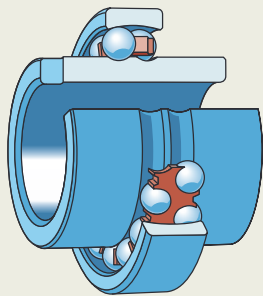

Fig. 9

Axial location of bearings with an extended inner ring

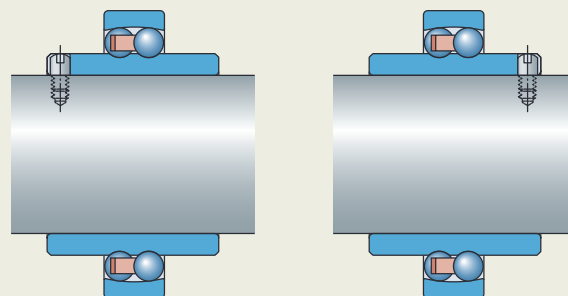
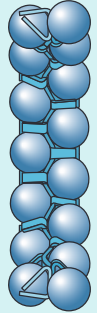
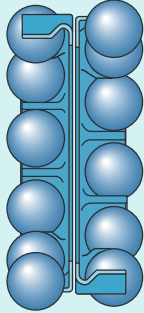
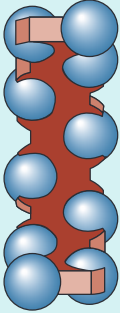
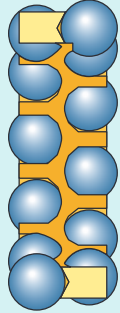
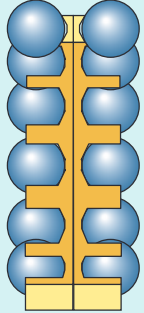

Table 4

Cages for self-aligning ball bearings

					
Cage type	One-piece, ball centred	Two-piece, ball centred	One-piece snap-type, ball centred	One-piece, ball centred	Two-piece, ball centred
Material	Stamped steel	Stamped steel	PA66, glass fibre reinforced	Machined brass	Machined brass
Suffix	–	–	TN9	M (no designation suffix when $d \geq 150$ mm)	M (no designation suffix when $d \geq 150$ mm)

For bearings with non-standard cages, contact SKF.

Cages

Depending on their series and size, SKF self-aligning ball bearings are fitted with one of the cages shown in [table 4](#).

When used at high temperatures, some lubricants can have a detrimental effect on polyamide cages. For additional information about the suitability of cages, refer to *Cages*, [page 187](#).

Table 5

Permissible angular misalignment

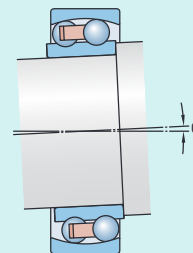

Bearings/series	Misalignment α
–	°
108, 126, 127, 129, 135	3
12 (E)	2,5
13 (E)	3
22 (E)	2,5
22 E-2RS1	1,5
23 (E)	3
23 E-2RS1	1,5
112 (E)	2,5
130, 139	3



Bearing data

Dimension standards	Boundary dimensions: ISO 15 Except for: <ul style="list-style-type: none"> • Bearings with an extended inner ring
Tolerances For additional information → page 35	Normal Except for: <ul style="list-style-type: none"> • Bearings with an extended inner ring: bore to tolerance class JS7 (table 3, page 441) in accordance with ISO 286-2 Values: ISO 492 (table 2, page 38)
Internal clearance For additional information → page 182	Normal, C3 Check availability of C2 (cylindrical bore only) Except for: <ul style="list-style-type: none"> • Bearings in the 130 and 139 series: C3 • Bearings with an extended inner ring: ranging from the minimum value of C2 to the maximum value of Normal Values: ISO 5753-1 (table 6, page 444) Values are valid for unmounted bearings under zero measuring load.
Permissible misalignment	Guideline values for normal operating condition (table 5). Whether these values can be fully exploited depends on the design of the adjacent components, such as external seals.

Radial internal clearance of self-aligning ball bearings

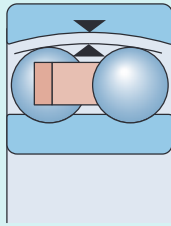

Bearings with a cylindrical bore

Bore diameter d		Radial internal clearance					
>	≤	C2		Normal		C3	
		min.	max.	min.	max.	min.	max.
mm		μm					
2,5	6	1	8	5	15	10	20
6	10	2	9	6	17	12	25
10	14	2	10	6	19	13	26
14	18	3	12	8	21	15	28
18	24	4	14	10	23	17	30
24	30	5	16	11	24	19	35
30	40	6	18	13	29	23	40
40	50	6	19	14	31	25	44
50	65	7	21	16	36	30	50
65	80	8	24	18	40	35	60
80	100	9	27	22	48	42	70
100	120	10	31	25	56	50	83
120	140	10	38	30	68	60	100
140	160	–	–	–	–	70	120
160	180	–	–	–	–	82	138
180	200	–	–	–	–	93	157
200	225	–	–	–	–	100	170
225	250	–	–	–	–	115	195

Bearings with a tapered bore

Bore diameter d		Radial internal clearance					
>	≤	C2		Normal		C3	
		min.	max.	min.	max.	min.	max.
mm		μm					
18	24	–	–	13	26	30	33
24	30	–	–	15	28	23	39
30	40	–	–	19	35	29	46
40	50	–	–	22	39	33	52
50	65	–	–	27	47	41	61
65	80	–	–	35	57	50	75
80	100	–	–	42	68	62	90
100	120	–	–	50	81	75	108



Loads		Symbols
Minimum load For additional information → page 106	$F_{rm} = k_r \left(\frac{v n}{1\ 000} \right)^{2/3} \left(\frac{d_m}{100} \right)^2$	Symbols B bearing width [mm] d bearing bore diameter [mm] d_m bearing mean diameter [mm] = 0,5 (d + D) e calculation factor (product tables, page 450) F_a axial load [kN] F_{ap} maximum permissible axial load [kN] F_r radial load [kN] F_{rm} minimum radial load [kN] k_r minimum load factor (product tables) n rotational speed [r/min] P equivalent dynamic bearing load [kN] P_0 equivalent static bearing load [kN] Y_0, Y_1, Y_2 calculation factors (product tables) v oil viscosity at operating temperature [mm ² /s]
Axial load carrying capacity Bearings mounted on an adapter sleeve on plain shafts without a fixed abutment: $F_{ap} = 0,003 B d$ provided the bearings are correctly mounted.		
Equivalent dynamic bearing load For additional information → page 91	$F_a/F_r \leq e \rightarrow P = F_r + Y_1 F_a$ $F_a/F_r > e \rightarrow P = 0,65 F_r + Y_2 F_a$	
Equivalent static bearing load For additional information → page 105	$P_0 = F_r + Y_0 F_a$	

Temperature limits

The permissible operating temperature for self-aligning ball bearings can be limited by:

- the dimensional stability of the bearing rings and balls
- the cage
- the seals
- the lubricant

Where temperatures outside the permissible range are expected, contact SKF.

Bearing rings and balls

SKF self-aligning ball bearings are heat stabilized up to 120 °C (250 °F).

Cages

Steel or brass cages can be used at the same operating temperatures as the bearing rings and balls. For temperature limits of polymer cages, refer to *Polymer cages*, [page 188](#).

Seals

The permissible operating temperature for NBR seals is -40 to +100 °C (-40 to +210 °F). Temperatures up to 120 °C (250 °F) can be tolerated for brief periods.

Typically, temperature peaks are at the seal lip.

Lubricants

Temperature limits for the greases used in sealed SKF self-aligning ball bearings are provided in [table 1, page 441](#). For temperature limits of other SKF greases, refer to *Selecting a suitable SKF grease*, [page 116](#).

When using lubricants not supplied by SKF, temperature limits should be evaluated according to the SKF traffic light concept ([page 117](#)).

Permissible speed Bearings on sleeves

The speed ratings in the **product tables** indicate:

- the **reference speed**, which enables a quick assessment of the speed capabilities from a thermal frame of reference
- the **limiting speed**, which is a mechanical limit that should not be exceeded unless the bearing design and the application are adapted for higher speeds

For additional information, refer to *Operating temperature and speed*, [page 130](#).

Design considerations

Ball protrusion

The balls of some bearings in the 12 and 13 series protrude from the side faces of the bearing ([fig. 10](#)). The values of the protrusion are listed in the [product table](#), [page 457](#), and should be considered when designing components in close proximity to the bearing.

Self-aligning ball bearings with a tapered bore can be mounted with:

- an adapter sleeve on plain or stepped shafts ([fig. 11](#))
- a withdrawal sleeve on stepped shafts ([fig. 12](#))

Adapter sleeves are supplied complete with a locking device.

For appropriate SKF adapter sleeves, refer to the [product table](#), [page 458](#).

When using sealed bearings, make sure appropriate SKF adapter sleeve assemblies (e.g. E design sleeve, refer to the [product table](#)) are used to prevent the locking device from interfering with the seal ([fig. 13](#)). Alternatively, use a spacer ring between the bearing and the lock washer.

For additional information

- *Adapter sleeves*, [page 1065](#)
- *Withdrawal sleeves*, [page 1087](#)

Bearings with an extended inner ring

When two of these bearings are used to support a shaft, to locate the shaft axially the inner ring slots must be arranged facing towards or away from each other ([fig. 9](#), [page 441](#)).

Fig. 10

Protrusion of balls from side faces

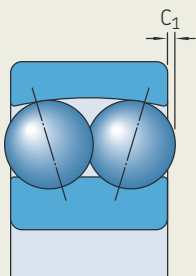
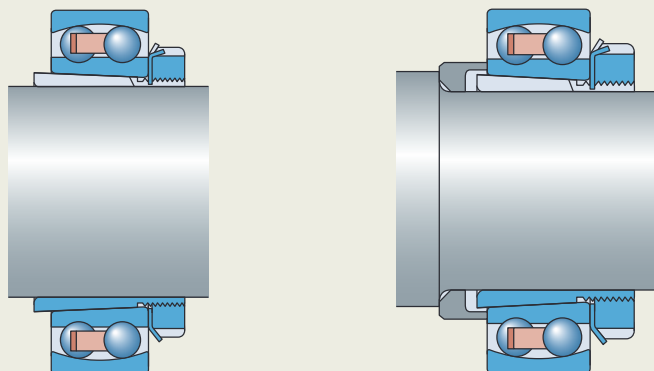

Fig. 11

Bearings with a tapered bore mounted with an adapter sleeve



On a plain shaft

On a stepped shaft

Appropriate bearing housings

Appropriate SKF bearing housings are available in a variety of designs and sizes for a wide range of applications. The designs include:

- SNL, SE plummer (pillow) block housings in the 2, 3, 5 and 6 series
- FNL flanged housings
- SAF plummer (pillow) block housings for inch shafts

Additional information about SKF bearing housings is available online at skf.com/housings.

Mounting

Mounting bearings with a cylindrical bore

Refer to *Mounting bearings with a cylindrical bore*, [page 201](#).

Mounting bearings with a tapered bore

Bearings with a tapered bore are mounted with an interference fit, by using one of the following methods:

1 Feeling the clearance reduction by turning and swivelling the outer ring (fig. 14)

- This method is valid for bearings with Normal radial clearance (not for sealed bearings).
- The clearance reduction in the bearing is sufficient when the outer ring can be turned easily, but a slight resistance is felt when it is swivelled out.

2 Measuring the lock nut tightening angle (table 7, page 448)

3 Measuring the axial drive-up (table 7)

4 Applying the SKF Drive-up Method

For bearings with $d \geq 50$ mm, SKF recommends using the SKF Drive-up Method. This is a fast, reliable and safe method to determine the appropriate interference fit. Additional information is available online at skf.com/drive-up.

For additional information about these mounting methods, refer to *Mounting bearings with a tapered bore*, [page 203](#), or the *SKF bearing maintenance handbook*.



Fig. 12

Bearing with a tapered bore mounted with a withdrawal sleeve on a stepped shaft

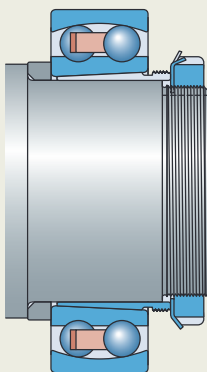

Fig. 13

Sealed bearing with a tapered bore mounted with an E design adapter sleeve

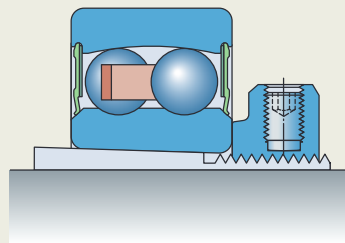

Fig. 14

Check clearance reduction

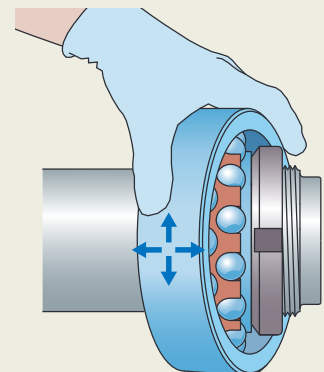
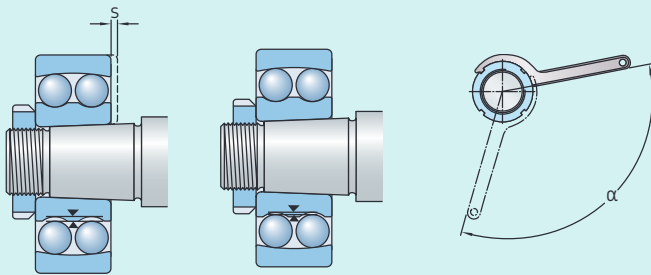

Table 7

Drive-up data for self-aligning ball bearings with a tapered bore



Bore diameter d	Axial drive-up s ¹⁾²⁾	Lock nut tightening angle $\alpha^{2)}$
mm	mm	°
20	0,22	80
25	0,22	55
30	0,22	55
35	0,30	70
40	0,30	70
45	0,35	80
50	0,35	80
55	0,40	75
60	0,40	75
65	0,40	80
70	0,40	80
75	0,45	85
80	0,45	85
85	0,60	110
90	0,60	110
95	0,60	110
100	0,60	110
110	0,70	125
120	0,70	125

¹⁾ Not valid for the SKF Drive-up Method.

²⁾ The listed values are valid only for solid steel shafts and general applications. They are to be used as guideline values only, as it is difficult to establish an exact starting position. Also, the axial drive-up, s, differs slightly between the different bearings series.

Designation system

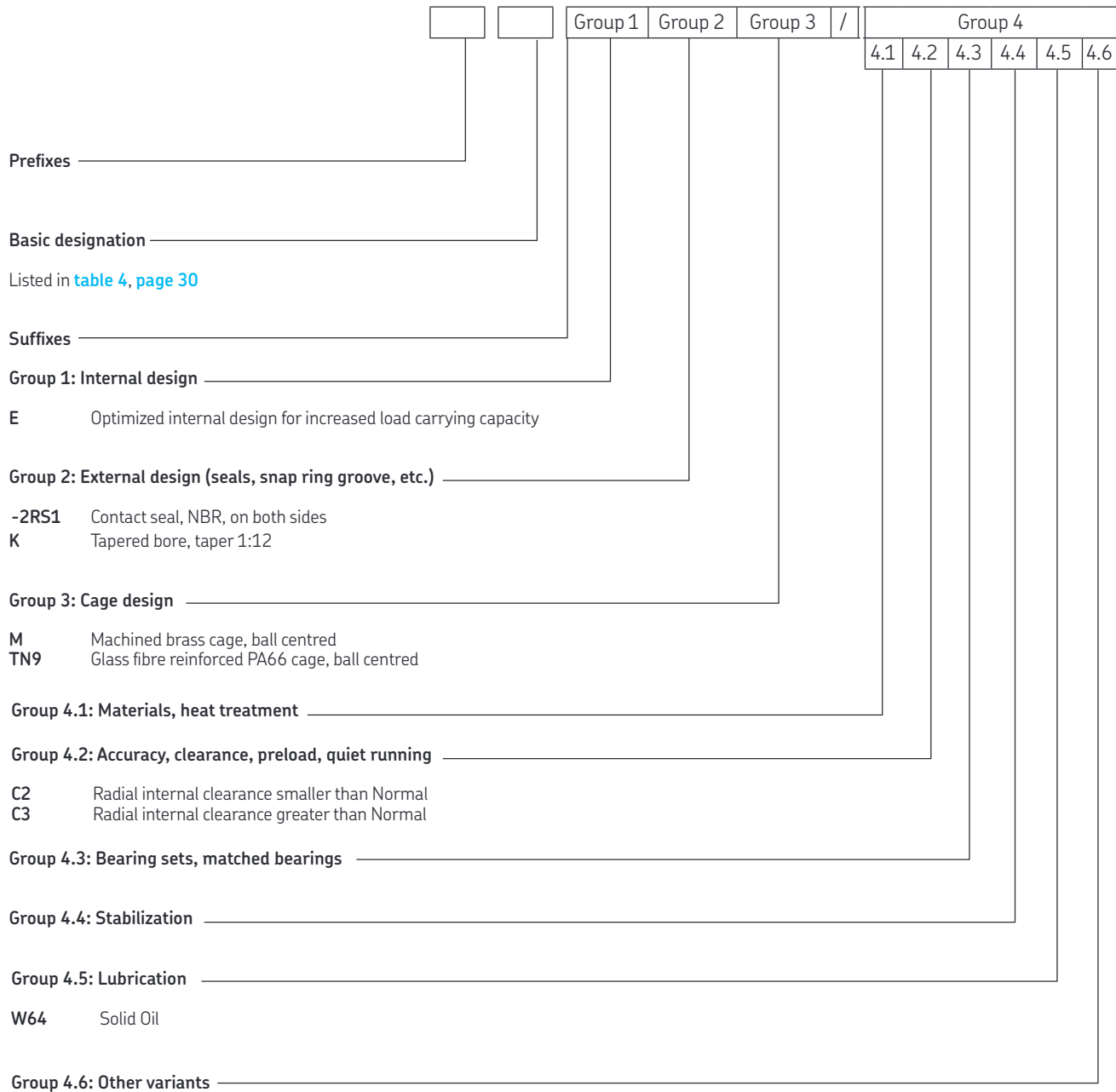

4.1 Self-aligning ball bearings

d 5 – 20 mm

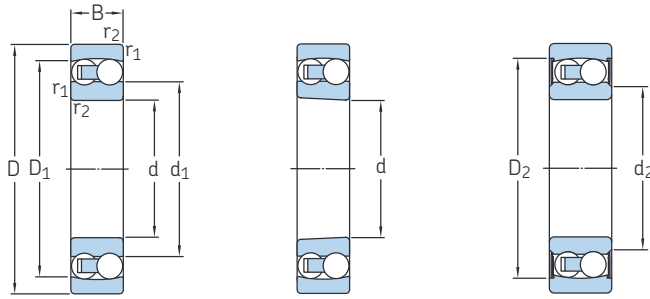

Cylindrical bore

Tapered bore

Sealed

4.1



Principal dimensions			Basic load ratings		Fatigue load limit	Speed ratings		Mass	Designations	
d	D	B	C	C ₀	P _u	Reference speed	Limiting speed		Bearing with cylindrical bore	tapered bore
mm			kN		kN	r/min		kg	–	
5	19	6	2,51	0,48	0,025	63 000	45 000	0,009	▶ 135 TN9	–
6	19	6	2,51	0,48	0,025	70 000	45 000	0,009	▶ 126 TN9	–
7	22	7	2,65	0,56	0,029	63 000	40 000	0,014	▶ 127 TN9	–
8	22	7	2,65	0,56	0,029	60 000	40 000	0,014	▶ 108 TN9	–
9	26	8	3,9	0,82	0,043	60 000	38 000	0,022	▶ 129 TN9	–
10	30	9	5,53	1,18	0,061	56 000	36 000	0,034	▶ 1200 ETN9	–
	30	14	5,53	1,18	0,06	–	17 000	0,048	▶ 2200 E-2RS1TN9	–
	30	14	8,06	1,73	0,09	50 000	34 000	0,047	▶ 2200 ETN9	–
12	32	10	6,24	1,43	0,072	50 000	32 000	0,04	▶ 1201 ETN9	–
	32	14	6,24	1,43	0,08	–	16 000	0,053	▶ 2201 E-2RS1TN9	–
	32	14	8,52	1,9	0,098	45 000	30 000	0,053	▶ 2201 ETN9	–
15	37	12	9,36	2,16	0,12	40 000	28 000	0,067	▶ 1301 ETN9	–
	37	17	11,7	2,7	0,14	38 000	28 000	0,095	2301	–
	35	11	7,41	1,76	0,09	45 000	28 000	0,049	▶ 1202 ETN9	–
17	35	14	7,41	1,76	0,09	–	14 000	0,058	▶ 2202 E-2RS1TN9	–
	35	14	8,71	2,04	0,11	38 000	26 000	0,06	▶ 2202 ETN9	–
	42	13	10,8	2,6	0,14	34 000	24 000	0,094	▶ 1302 ETN9	–
20	42	17	10,8	2,6	0,14	–	12 000	0,11	▶ 2302 E-2RS1TN9	–
	42	17	11,9	2,9	0,15	32 000	24 000	0,12	▶ 2302	–
	40	12	8,84	2,2	0,12	38 000	24 000	0,073	▶ 1203 ETN9	–
17	40	16	8,84	2,2	0,12	–	12 000	0,089	▶ 2203 E-2RS1TN9	–
	40	16	10,6	2,55	0,14	34 000	24 000	0,088	▶ 2203 ETN9	–
	47	14	12,7	3,4	0,18	28 000	20 000	0,12	▶ 1303 ETN9	–
20	47	19	12,7	3,4	0,18	–	11 000	0,16	▶ 2303 E-2RS1TN9	–
	47	19	14,3	3,55	0,19	30 000	22 000	0,18	2303 M	–
	47	14	12,7	3,4	0,18	32 000	20 000	0,12	▶ 1204 ETN9	1204 EKTN9
20	47	18	12,7	3,4	0,18	–	10 000	0,14	▶ 2204 E-2RS1TN9	–
	47	18	16,8	4,15	0,22	28 000	20 000	0,14	▶ 2204 ETN9	–
	52	15	14,3	4	0,21	26 000	18 000	0,16	▶ 1304 ETN9	–
20	52	21	14,3	4	0,21	–	9 000	0,21	▶ 2304 E-2RS1TN9	–
	52	21	18,2	4,75	0,24	26 000	19 000	0,22	2304 TN9	–

▶ Popular item

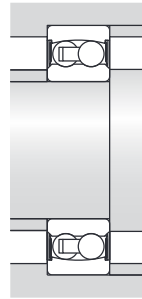
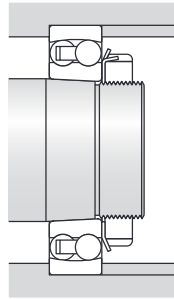
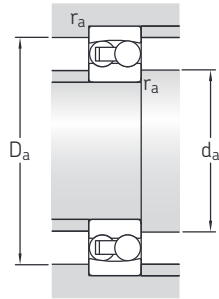

Dimensions						Abutment and fillet dimensions					Calculation factors				
d	d ₁ , d ₂	D ₁ , D ₂	C ₁	b	K	r _{1,2} min.	d _a min.	d _a max.	D _a max.	r _a max.	k _r	e	Y ₁	Y ₂	Y ₀
mm							mm				-				
5	10,3	15,4	-	-	-	0,3	7,4	-	16,6	0,3	0,045	0,33	1,9	3	2
6	10,3	15,4	-	-	-	0,3	8,4	-	16,6	0,3	0,04	0,33	1,9	3	2
7	12,7	17,6	-	-	-	0,3	9,4	-	19,6	0,3	0,04	0,33	1,9	3	2
8	12,7	17,6	-	-	-	0,3	10,4	-	19,6	0,3	0,03	0,33	1,9	3	2
9	14,8	20,4	-	-	-	0,3	11,4	-	23,6	0,3	0,04	0,33	1,9	3	2
10	16,5	23,5	-	-	-	0,6	14,2	-	25,8	0,6	0,04	0,33	1,9	3	2
	14,6	24,8	-	-	-	0,6	14	14	25,8	0,6	0,045	0,33	1,9	3	2
	15,3	24,3	-	-	-	0,6	14,2	-	25,8	0,6	0,045	0,54	1,15	1,8	1,3
12	18,2	25,7	-	-	-	0,6	16,2	-	27,8	0,6	0,04	0,33	1,9	3	2
	15,5	27,4	-	-	-	0,6	15,5	15,5	27,8	0,6	0,045	0,33	1,9	3	2
	17,4	26,4	-	-	-	0,6	16,2	-	27,8	0,6	0,045	0,5	1,25	2	1,3
15	20,2	29,5	-	-	-	1	17,6	-	31,4	1	0,04	0,35	1,8	2,8	1,8
	18,9	29,1	-	-	-	1	17,6	-	31,4	1	0,05	0,6	1,05	1,6	1,1
	21,1	28,9	-	-	-	0,6	19,2	-	30,8	0,6	0,04	0,33	1,9	3	2
17	19	30,4	-	-	-	0,6	19	19	30,8	0,6	0,045	0,33	1,9	3	2
	20,8	29,5	-	-	-	0,6	19,2	-	30,8	0,6	0,045	0,43	1,5	2,3	1,6
	23,9	34,3	-	-	-	1	20,6	-	36,4	1	0,04	0,31	2	3,1	2,2
20	20,3	36,3	-	-	-	1	20	20	36,4	1	0,05	0,31	2	3,1	2,2
	23,1	33,3	-	-	-	1	20,6	-	36,4	1	0,05	0,52	1,2	1,9	1,3
	24	32,9	-	-	-	0,6	21,2	-	35,8	0,6	0,04	0,31	2	3,1	2,2
23	21,1	35	-	-	-	0,6	21	21	35,8	0,6	0,045	0,31	2	3,1	2,2
	23,8	33,4	-	-	-	0,6	21,2	-	35,8	0,6	0,045	0,43	1,5	2,3	1,6
	28,8	40	-	-	-	1	22,6	-	41,4	1	0,04	0,3	2,1	3,3	2,2
26	25,5	41,3	-	-	-	1	22	25,5	41,4	1	0,05	0,3	2,1	3,3	2,2
	26,1	37,2	-	-	-	1	22,6	-	41,4	1	0,05	0,52	1,2	1,9	1,3
	28,8	40	-	-	-	1	25,6	-	41,4	1	0,04	0,3	2,1	3,3	2,2
30	25,9	41,3	-	-	-	1	25	25,5	41,4	1	0,045	0,3	2,1	3,3	2,2
	27,3	40	-	-	-	1	25,6	-	41,4	1	0,045	0,4	1,6	2,4	1,6
	33,3	44,6	-	-	-	1	27	-	45	1	0,04	0,28	2,2	3,5	2,5
35	28,6	46,3	-	-	-	1,1	26,5	28,5	45	1,1	0,05	0,28	2,2	3,5	2,5
	29,1	41,9	-	-	-	1,1	27	-	45	1,1	0,05	0,52	1,2	1,9	1,3



4.1 Self-aligning ball bearings

d 25 – 45 mm

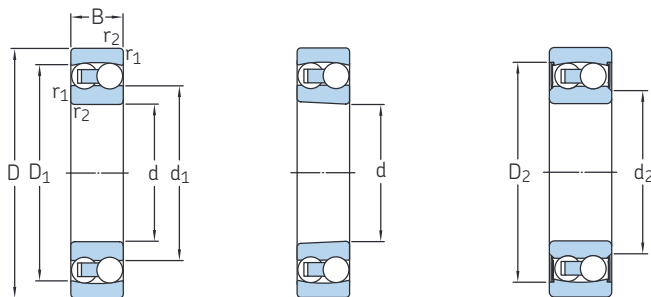

Cylindrical bore

Tapered bore

Sealed

Principal dimensions			Basic load ratings		Fatigue load limit	Speed ratings		Mass	Designations	
d	D	B	C	C ₀	P _u	Reference speed	Limiting speed		Bearing with cylindrical bore	tapered bore
mm			kN		kN	r/min		kg	–	
25	52	15	14,3	4	0,21	28 000	18 000	0,14	▶ 1205 ETN9	▶ 1205 EKTN9
	52	18	14,3	4	0,21	–	9 000	0,16	▶ 2205 E-2RS1TN9	▶ 2205 E-2RS1KTN9
	52	18	16,8	4,4	0,23	26 000	18 000	0,16	▶ 2205 ETN9	▶ 2205 EKTN9
	62	17	19	5,4	0,28	22 000	15 000	0,26	▶ 1305 ETN9	▶ 1305 EKTN9
	62	24	19	5,4	0,28	–	7 500	0,34	▶ 2305 E-2RS1TN9	▶ 2305 E-2RS1KTN9
	62	24	27	7,1	0,37	22 000	16 000	0,34	▶ 2305 ETN9	▶ 2305 EKTN9
30	62	16	15,6	4,65	0,24	24 000	15 000	0,22	▶ 1206 ETN9	▶ 1206 EKTN9
	62	20	15,6	4,65	0,24	–	7 500	0,26	▶ 2206 E-2RS1TN9	▶ 2206 E-2RS1KTN9
	62	20	23,8	6,7	0,35	22 000	15 000	0,26	▶ 2206 ETN9	▶ 2206 EKTN9
	72	19	22,5	6,8	0,36	19 000	13 000	0,39	▶ 1306 ETN9	▶ 1306 EKTN9
	72	27	22,5	6,8	0,36	–	6 700	0,51	▶ 2306 E-2RS1TN9	▶ 2306 E-2RS1KTN9
	72	27	31,2	8,8	0,45	18 000	13 000	0,5	▶ 2306	▶ 2306 K
35	72	17	19	6	0,31	20 000	13 000	0,32	▶ 1207 ETN9	▶ 1207 EKTN9
	72	23	19	6	0,31	–	6 300	0,41	▶ 2207 E-2RS1TN9	▶ 2207 E-2RS1KTN9
	72	23	30,2	8,8	0,455	18 000	12 000	0,4	▶ 2207 ETN9	▶ 2207 EKTN9
	80	21	26,5	8,5	0,43	16 000	11 000	0,51	▶ 1307 ETN9	▶ 1307 EKTN9
	80	31	26,5	8,5	0,43	–	5 600	0,7	▶ 2307 E-2RS1TN9	▶ 2307 E-2RS1KTN9
	80	31	39,7	11,2	0,59	16 000	12 000	0,68	▶ 2307 ETN9	▶ 2307 EKTN9
40	80	18	19,9	6,95	0,36	18 000	11 000	0,42	▶ 1208 ETN9	▶ 1208 EKTN9
	80	23	19,9	6,95	0,36	–	5 600	0,5	▶ 2208 E-2RS1TN9	▶ 2208 E-2RS1KTN9
	80	23	31,9	10	0,51	16 000	11 000	0,51	▶ 2208 ETN9	▶ 2208 EKTN9
	90	23	33,8	11,2	0,57	14 000	9 500	0,68	▶ 1308 ETN9	▶ 1308 EKTN9
	90	33	33,8	11,2	0,57	–	5 000	0,96	▶ 2308 E-2RS1TN9	▶ 2308 E-2RS1KTN9
	90	33	54	16	0,82	14 000	10 000	0,93	▶ 2308 ETN9	▶ 2308 EKTN9
45	85	19	22,9	7,8	0,4	17 000	11 000	0,47	▶ 1209 ETN9	▶ 1209 EKTN9
	85	23	22,9	7,8	0,4	–	5 300	0,53	▶ 2209 E-2RS1TN9	▶ 2209 E-2RS1KTN9
	85	23	32,5	10,6	0,54	15 000	10 000	0,55	▶ 2209 ETN9	▶ 2209 EKTN9
	100	25	39	13,4	0,7	12 000	8 500	0,96	▶ 1309 ETN9	▶ 1309 EKTN9
	100	36	39	13,4	0,7	–	4 500	1,3	▶ 2309 E-2RS1TN9	▶ 2309 E-2RS1KTN9
	100	36	63,7	19,3	1	13 000	9 000	1,25	▶ 2309 ETN9	▶ 2309 EKTN9

▶ Popular item

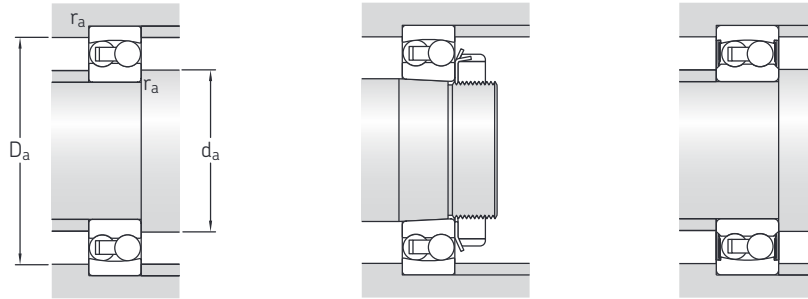

Dimensions						Abutment and fillet dimensions					Calculation factors				
d	d ₁ , d ₂	D ₁ , D ₂	C ₁	b	K	r _{1,2} min.	d _a min.	d _a max.	D _a max.	r _a max.	k _r	e	Y ₁	Y ₂	Y ₀
mm							mm				-				
25	33,3	44,6	-	-	-	1	30,6	-	46,4	1	0,04	0,28	2,2	3,5	2,5
	31	46,3	-	-	-	1	30,6	31	46,4	1	0,045	0,28	2,2	3,5	2,5
	32,2	45,1	-	-	-	1	30,6	-	46,4	1	0,045	0,35	1,8	2,8	1,8
	38	50,7	-	-	-	1,1	32	-	55	1,1	0,04	0,28	2,2	3,5	2,5
	32,8	52,7	-	-	-	1,1	32	32,5	55	1,1	0,05	0,28	2,2	3,5	2,5
	35,5	52,3	-	-	-	1,1	32	-	55	1,1	0,05	0,44	1,4	2,2	1,4
30	40,3	51,9	-	-	-	1	35,6	-	56,4	1	0,04	0,25	2,5	3,9	2,5
	36,7	54,1	-	-	-	1	35,6	36,5	56,4	1	0,045	0,25	2,5	3,9	2,5
	38,7	54	-	-	-	1	35,6	-	56,4	1	0,045	0,33	1,9	3	2
	45,1	59,1	-	-	-	1,1	37	-	65	1,1	0,04	0,25	2,5	3,9	2,5
	40,4	61,9	-	-	-	1,1	37	40	65	1,1	0,05	0,25	2,5	3,9	2,5
	41,9	59,8	-	-	-	1,1	37	-	65	1,1	0,05	0,44	1,4	2,2	1,4
35	47	60,9	-	-	-	1,1	42	-	65	1,1	0,04	0,23	2,7	4,2	2,8
	42,7	62,7	-	-	-	1,1	42	42,5	65	1,1	0,045	0,23	2,7	4,2	2,8
	45,3	62,9	-	-	-	1,1	42	-	65	1,1	0,045	0,31	2	3,1	2,2
	51,5	67,5	-	-	-	1,5	44	-	71	1,5	0,04	0,25	2,5	3,9	2,5
	43,7	69,2	-	-	-	1,5	43,5	43,5	71	1,5	0,05	0,25	2,5	3,9	2,5
	46,7	67	-	-	-	1,5	44	-	71	1,5	0,05	0,46	1,35	2,1	1,4
40	53,8	67,5	-	-	-	1,1	47	-	73	1,1	0,04	0,22	2,9	4,5	2,8
	49	69,8	-	-	-	1,1	47	49	73	1,1	0,045	0,22	2,9	4,5	2,8
	52,3	70,2	-	-	-	1,1	47	-	73	1,1	0,045	0,28	2,2	3,5	2,5
	61,4	80,2	-	-	-	1,1	49	-	81	1,1	0,04	0,23	2,7	4,2	2,8
	55,4	81,8	-	-	-	1,5	49	55	81	1,5	0,05	0,23	2,7	4,2	2,8
	53,7	77,8	-	-	-	1,5	49	-	81	1,5	0,05	0,4	1,6	2,4	1,6
45	57,5	72,5	-	-	-	1,1	52	-	78	1,1	0,04	0,21	3	4,6	3,2
	52,9	75,3	-	-	-	1,1	52	53	78	1,1	0,045	0,21	3	4,6	3,2
	55,3	73,2	-	-	-	1,1	52	-	78	1,1	0,045	0,26	2,4	3,7	2,5
	67,7	87,8	-	-	-	1,5	54	-	91	1,5	0,04	0,23	2,7	4,2	2,8
	60,9	90	-	-	-	1,5	54	60,5	91	1,5	0,05	0,23	2,7	4,2	2,8
	60,1	86	-	-	-	1,5	54	-	91	1,5	0,05	0,33	1,9	3	2



4.1 Self-aligning ball bearings

d 50 – 80 mm

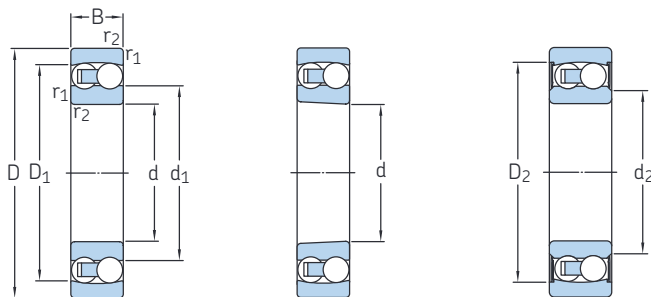

Cylindrical bore

Tapered bore

Sealed

4.1



Principal dimensions			Basic load ratings		Fatigue load limit	Speed ratings		Mass	Designations	
d	D	B	dynamic	static		Reference speed	Limiting speed		Bearing with cylindrical bore	tapered bore
mm			kN		kN	r/min		kg	–	
50	90	20	26,5	9,15	0,48	16 000	10 000	0,53	▶ 1210 ETN9	▶ 1210 EKTN9
	90	23	22,9	8,15	0,42	–	4 800	0,57	▶ 2210 E-2RS1TN9	▶ 2210 E-2RS1KTN9
	90	23	33,8	11,2	0,57	14 000	9 500	0,6	▶ 2210 ETN9	▶ 2210 EKTN9
	110	27	43,6	14	0,72	12 000	8 000	1,2	▶ 1310 ETN9	▶ 1310 EKTN9
	110	40	43,6	14	0,72	–	4 000	1,65	▶ 2310 E-2RS1TN9	▶ 2310 E-2RS1KTN9
	110	40	63,7	20	1,04	14 000	9 500	1,65	▶ 2310	▶ 2310 K
55	100	21	27,6	10,6	0,54	14 000	9 000	0,71	▶ 1211 ETN9	▶ 1211 EKTN9
	100	25	27,6	10,6	0,54	–	4 300	0,79	▶ 2211 E-2RS1TN9	▶ 2211 E-2RS1KTN9
	100	25	39	13,4	0,7	12 000	8 500	0,81	▶ 2211 ETN9	▶ 2211 EKTN9
	120	29	50,7	18	0,92	11 000	7 500	1,6	▶ 1311 ETN9	▶ 1311 EKTN9
	120	43	76,1	24	1,25	11 000	7 500	2,1	▶ 2311	▶ 2311 K
60	110	22	31,2	12,2	0,62	12 000	8 500	0,9	▶ 1212 ETN9	▶ 1212 EKTN9
	110	28	31,2	12,2	0,62	–	3 800	1,05	▶ 2212 E-2RS1TN9	▶ 2212 E-2RS1KTN9
	110	28	48,8	17	0,88	11 000	8 000	1,1	▶ 2212 ETN9	▶ 2212 EKTN9
	130	31	58,5	22	1,12	9 000	6 300	1,95	▶ 1312 ETN9	▶ 1312 EKTN9
	130	46	87,1	28,5	1,46	9 500	7 000	2,6	▶ 2312	▶ 2312 K
65	120	23	35,1	14	0,72	11 000	7 000	1,15	▶ 1213 ETN9	▶ 1213 EKTN9
	120	31	35,1	14	0,72	–	3 600	1,4	▶ 2213 E-2RS1TN9	▶ 2213 E-2RS1KTN9
	120	31	57,2	20	1,02	10 000	7 000	1,45	▶ 2213 ETN9	▶ 2213 EKTN9
	140	33	65	25,5	1,25	8 500	6 000	2,45	▶ 1313 ETN9	▶ 1313 EKTN9
	140	48	95,6	32,5	1,66	9 000	6 300	3,25	▶ 2313	▶ 2313 K
70	125	24	35,8	14,6	0,75	11 000	7 000	1,25	▶ 1214 ETN9	–
	125	31	35,8	14,6	0,75	–	3 400	1,45	▶ 2214 E-2RS1TN9	–
	125	31	44,2	17	0,88	10 000	6 700	1,5	▶ 2214	–
	150	35	74,1	27,5	1,34	8 500	6 000	3	▶ 1314	–
	150	51	111	37,5	1,86	8 000	6 000	3,9	▶ 2314	–
75	130	25	39	15,6	0,8	10 000	6 700	1,35	▶ 1215	▶ 1215 K
	130	31	58,5	22	1,12	9 000	6 300	1,6	▶ 2215 ETN9	▶ 2215 EKTN9
	160	37	79,3	30	1,43	8 000	5 600	3,55	▶ 1315	▶ 1315 K
	160	55	124	43	2,04	7 500	5 600	4,7	▶ 2315	▶ 2315 K
80	140	26	39,7	17	0,83	9 500	6 000	1,65	▶ 1216	▶ 1216 K
	140	33	65	25,5	1,25	8 500	6 000	2	▶ 2216 ETN9	▶ 2216 EKTN9
	170	39	88,4	33,5	1,5	7 500	5 300	4,2	▶ 1316	▶ 1316 K
	170	58	135	49	2,24	7 000	5 300	6,1	▶ 2316	▶ 2316 K

▶ Popular item

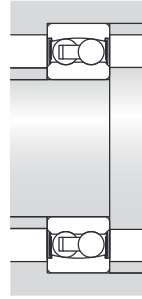
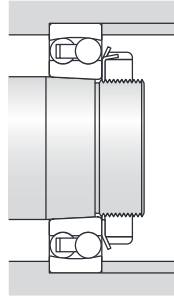
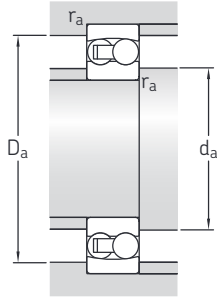

Dimensions						Abutment and fillet dimensions					Calculation factors				
d	d ₁ , d ₂	D ₁ , D ₂	C ₁	b	K	r _{1,2} min.	d _a min.	d _a max.	D _a max.	r _a max.	k _r	e	Y ₁	Y ₂	Y ₀
mm						mm					-				
50	61,7	78,1	-	-	-	1,1	57	-	83	1,1	0,04	0,21	3	4,6	3,2
	57,7	79,4	-	-	-	1,1	57	58	83	1,1	0,045	0,2	3,2	4,9	3,2
	61,4	80,2	-	-	-	1,1	57	-	83	1,1	0,045	0,23	2,7	4,2	2,8
50	70,3	92,6	-	-	-	2	61	-	99	2	0,04	0,24	2,6	4,1	2,8
	62,9	95,2	-	-	-	2	61	62,5	99	2	0,05	0,24	2,6	4,1	2,8
	66	92,5	-	-	-	2	61	-	99	2	0,05	0,43	1,5	2,3	1,6
	66	92,5	-	-	-	2	61	-	99	2	0,05	0,43	1,5	2,3	1,6
55	70,3	86,5	-	-	-	1,5	64	-	91	1,5	0,04	0,19	3,3	5,1	3,6
	65,9	88,5	-	-	-	1,5	64	65,5	91	1,5	0,045	0,19	3,3	5,1	3,6
	67,7	87,8	-	-	-	1,5	64	-	91	1,5	0,045	0,23	2,7	4,2	2,8
55	77,9	102	-	-	-	2	66	-	109	2	0,04	0,23	2,7	4,2	2,8
	72	101	-	-	-	2	66	-	109	2	0,05	0,4	1,6	2,4	1,6
60	78	95,6	-	-	-	1,5	69	-	101	1,5	0,04	0,19	3,3	5,1	3,6
	73,2	97	-	-	-	1,5	69	73	101	1,5	0,045	0,19	3,3	5,1	3,6
	74,4	96,9	-	-	-	1,5	69	-	101	1,5	0,045	0,24	2,6	4,1	2,8
60	91,6	117	-	-	-	2,1	72	-	118	2	0,04	0,22	2,9	4,5	2,8
	77,1	110	-	-	-	2,1	72	-	118	2	0,05	0,33	1,9	3	2
65	85,1	104	-	-	-	1,5	74	-	111	1,5	0,04	0,18	3,5	5,4	3,6
	79,3	106	-	-	-	1,5	74	79	111	1,5	0,045	0,18	3,5	5,4	3,6
	80,6	106	-	-	-	1,5	74	-	111	1,5	0,045	0,24	2,6	4,1	2,8
65	99	126	-	-	-	2	77	-	128	2	0,04	0,22	2,9	4,5	2,8
	86	120	-	-	-	2,1	77	-	128	2	0,05	0,37	1,7	2,6	1,8
70	87,4	107	-	-	-	1,5	79	-	116	1,5	0,04	0,18	3,5	5,4	3,6
	81,4	109	-	-	-	1,5	79	81	116	1,5	0,045	0,18	3,5	5,4	3,6
	88	109	-	-	-	1,5	79	-	116	1,5	0,04	0,27	2,3	3,6	2,5
70	97,5	127	-	-	-	2,1	82	-	138	2	0,045	0,22	2,9	4,5	2,8
	92	129	-	-	-	2,1	82	-	138	2	0,05	0,37	1,7	2,6	1,8
75	93	115	-	-	-	1,5	84	-	121	1,5	0,04	0,17	3,7	5,7	4
	91,6	117	-	-	-	1,5	84	-	121	1,5	0,045	0,22	2,9	4,5	2,8
75	104	136	-	-	-	2,1	87	-	148	2	0,045	0,22	2,9	4,5	2,8
	97,8	137	-	-	-	2,1	87	-	148	2	0,05	0,37	1,7	2,6	1,8
80	102	123	-	-	-	2	91	-	129	2	0,04	0,16	3,9	6,1	4
	99	126	-	-	-	2	91	-	129	2	0,045	0,22	2,9	4,5	2,8
80	110	145	-	-	-	2,1	92	-	158	2	0,045	0,22	2,9	4,5	2,8
	104	146	-	-	-	2,1	92	-	158	2	0,05	0,37	1,7	2,6	1,8



4.1 Self-aligning ball bearings

d 85 – 240 mm

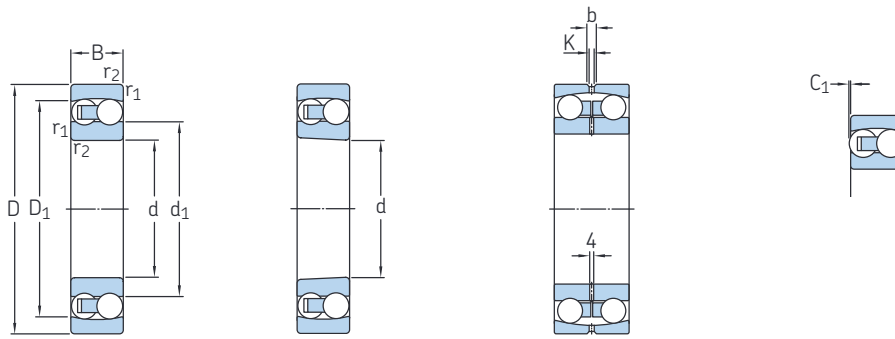

Cylindrical bore

Tapered bore

130.., 139..

4.1



Principal dimensions			Basic load ratings		Fatigue load limit	Speed ratings		Mass	Designations	
d	D	B	C	C ₀	P _u	Reference speed	Limiting speed		Bearing with cylindrical bore	tapered bore
mm			kN		kN	r/min		kg	–	
85	150	28	48,8	20,8	0,98	9 000	5 600	2,05	▶ 1217	▶ 1217 K
	150	36	58,5	23,6	1,12	8 000	5 600	2,5	▶ 2217	▶ 2217 K
	180	41	97,5	38	1,7	7 000	4 800	5	1317	▶ 1317 K
	180	60	140	51	2,28	6 700	4 800	7,05	2317	–
90	160	30	57,2	23,6	1,08	8 500	5 300	2,5	▶ 1218	▶ 1218 K
	160	40	70,2	28,5	1,32	7 500	5 300	3,4	▶ 2218	▶ 2218 K
	190	43	117	44	1,93	6 700	4 500	5,8	1318	1318 K
	190	64	151	57	2,5	6 300	4 500	8,45	2318	2318 K
95	170	32	63,7	27	1,2	8 000	5 000	3,1	1219	▶ 1219 K
	170	43	83,2	34,5	1,53	7 000	5 000	4,1	2219	2219 K
	200	45	133	51	2,16	6 300	4 300	6,7	1319	1319 K
	200	67	165	64	2,75	6 000	4 500	9,8	2319 M	2319 KM
100	180	34	68,9	30	1,29	7 500	4 800	3,7	▶ 1220	▶ 1220 K
	180	46	97,5	40,5	1,76	6 700	4 800	5	2220	2220 K
	215	47	143	57	2,36	6 000	4 000	8,3	1320	▶ 1320 K
	215	73	190	80	3,25	5 600	4 000	12,5	2320	2320 K
110	200	38	88,4	39	1,6	6 700	4 300	5,15	▶ 1222	▶ 1222 K
	200	53	124	52	2,12	6 000	4 300	7,1	2222	2222 K
	240	50	163	72	2,75	5 300	3 600	12	1322 M	1322 KM
120	215	42	119	53	2,12	6 300	4 000	6,75	1224 M	1224 KM
130	230	46	127	58,5	2,24	5 600	3 600	8,3	▶ 1226 M	1226 KM
150	225	56	57,2	23,6	0,88	5 600	3 400	7,5	13030	–
180	280	74	95,6	40	1,34	4 500	2 800	16	13036	–
200	280	60	60,5	29	0,97	4 300	2 600	10,5	13940	–
220	300	60	60,5	30,5	0,97	3 800	2 400	11	13944	–
240	320	60	60,5	32	0,98	3 800	2 200	11,5	13948	–

▶ Popular item

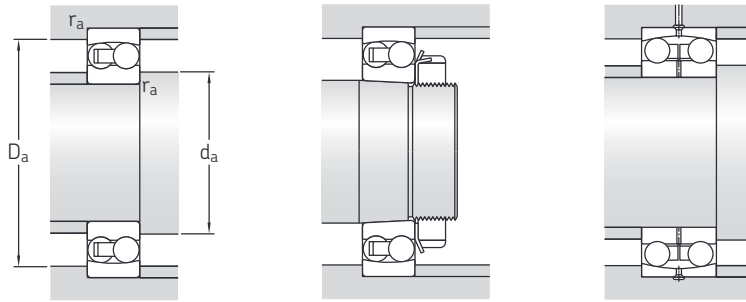

Dimensions					Abutment and fillet dimensions						Calculation factors				
d	d ₁ , d ₂	D ₁ , D ₂	C ₁	b	K	r _{1,2} min.	d _a min.	d _a max.	D _a max.	r _a max.	k _r	e	Y ₁	Y ₂	Y ₀
mm							mm				-				
85	107	131	-	-	-	2	96	-	139	2	0,04	0,17	3,7	5,7	4
	106	131	-	-	-	2	96	-	139	2	0,04	0,25	2,5	3,9	2,5
	117	153	-	-	-	3	99	-	166	3	0,045	0,22	2,9	4,5	2,8
	115	154	-	-	-	3	99	-	166	3	0,05	0,37	1,7	2,6	1,8
	115	154	-	-	-	3	99	-	166	3	0,05	0,37	1,7	2,6	1,8
90	112	139	-	-	-	2	101	-	149	2	0,04	0,17	3,7	5,7	4
	112	140	-	-	-	2	101	-	149	2	0,04	0,27	2,3	3,6	2,5
	122	163	1	-	-	3	104	-	176	3	0,045	0,22	2,9	4,5	2,8
	121	163	-	-	-	3	104	-	176	3	0,05	0,37	1,7	2,6	1,8
	127	171	1,5	-	-	3	109	-	186	3	0,045	0,23	2,7	4,2	2,8
95	120	149	-	-	-	2,1	107	-	158	2	0,04	0,17	3,7	5,7	4
	119	149	-	-	-	2,1	107	-	158	2	0,04	0,27	2,3	3,6	2,5
	127	171	1,5	-	-	3	109	-	186	3	0,045	0,23	2,7	4,2	2,8
	128	171	-	-	-	3	109	-	186	3	0,05	0,37	1,7	2,6	1,8
	127	171	1,5	-	-	3	109	-	186	3	0,05	0,37	1,7	2,6	1,8
100	127	156	-	-	-	2,1	112	-	168	2	0,04	0,17	3,7	5,7	4
	124	157	-	-	-	2,1	112	-	168	2	0,04	0,27	2,3	3,6	2,5
	136	182	2,5	-	-	3	114	-	201	3	0,045	0,23	2,7	4,2	2,8
	135	184	-	-	-	3	114	-	201	3	0,05	0,37	1,7	2,6	1,8
	136	182	2,5	-	-	3	114	-	201	3	0,05	0,37	1,7	2,6	1,8
110	140	174	-	-	-	2,1	122	-	188	2	0,04	0,17	3,7	5,7	4
	138	175	-	-	-	2,1	122	-	188	2	0,04	0,28	2,2	3,5	2,5
	154	203	2,5	-	-	3	124	-	226	3	0,045	0,22	2,9	4,5	2,8
	154	203	2,5	-	-	3	124	-	226	3	0,045	0,22	2,9	4,5	2,8
120	149	1,3	-	-	2,1	132	-	203	2	0,04	0,19	3,3	5,1	3,6	
130	163	202	1,3	-	-	3	144	-	216	3	0,04	0,19	3,3	5,1	3,6
150	175	204	-	8,3	4,5	2,1	161	-	214	2	0,02	0,24	2,6	4,1	2,8
180	212	250	-	13,9	7,5	2,1	191	-	269	2	0,02	0,25	2,5	3,9	2,5
200	229	258	-	8,3	4,5	2,1	211	-	269	2	0,015	0,19	3,3	5,1	3,6
220	248	278	-	8,3	4,5	2,1	231	-	289	2	0,015	0,18	3,5	5,4	3,6
240	268	298	-	8,3	4,5	2,1	251	-	309	2	0,015	0,16	3,9	6,1	4



4.2 Self-aligning ball bearings on an adapter sleeve

d 17 – 90 mm

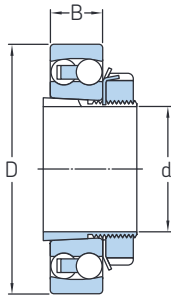

Open bearing on a standard sleeve



Sealed bearing on an E design sleeve

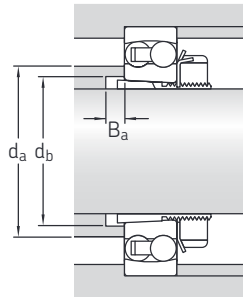

4.2



Principal dimensions			Abutment and fillet dimensions			Mass Bearing + sleeve	Designations Bearing ¹⁾	Sleeve ²⁾
d	D	B	d _a max.	d _b min.	B _a min.			
mm			mm			kg	–	
17	47	14	28,5	23	5	0,16	1204 EKTN9	H 204
20	52	15	33	28	5	0,21	▶ 1205 EKTN9	H 205
	52	18	31	28	5	0,23	2205 E-2RS1KTN9	H 305 E
	52	18	32	28	5	0,23	2205 EKTN9	H 305
25	62	17	37	28	6	0,33	1305 EKTN9	H 305
	62	24	32,5	29	5	0,42	2305 E-2RS1KTN9	H 2305
	62	24	35,5	29	5	0,42	2305 EKTN9	H 2305
	25	62	16	40	33	5	0,32	▶ 1206 EKTN9
62		20	36,5	33	5	0,36	2206 E-2RS1KTN9	H 306 E
62		20	38	33	5	0,36	2206 EKTN9	H 306
25	72	19	44	33	6	0,49	1306 EKTN9	H 306
	72	27	40	35	5	0,62	2306 E-2RS1KTN9	H 2306
	72	27	41	35	5	0,61	2306 K	H 2306
30	72	17	47	38	5	0,44	▶ 1207 EKTN9	H 207
	72	23	42,5	39	5	0,55	2207 E-2RS1KTN9	H 307 E
	72	23	45	39	5	0,54	2207 EKTN9	H 307
30	80	21	51	39	7	0,65	1307 EKTN9	H 307
	80	31	43,5	40	5	0,86	2307 E-2RS1KTN9	H 2307 E
	80	31	46	40	5	0,84	▶ 2307 EKTN9	H 2307
35	80	18	53	43	6	0,58	▶ 1208 EKTN9	H 208
	80	23	49	44	6	0,67	2208 E-2RS1KTN9	H 308 E
	80	23	52	44	6	0,58	2208 EKTN9	H 308
35	90	23	61	44	6	0,85	1308 EKTN9	H 308
	90	33	53	45	6	1,1	▶ 2308 EKTN9	H 2308
	90	33	55	45	6	1,2	2308 E-2RS1KTN9	H 2308
40	85	19	57	48	6	0,68	▶ 1209 EKTN9	H 209
	85	23	53	50	8	0,76	2209 E-2RS1KTN9	H 309 E
	85	23	55	50	8	0,78	2209 EKTN9	H 309
40	100	25	67	50	6	1,2	1309 EKTN9	H 309
	100	36	60	50	6	1,4	▶ 2309 EKTN9	H 2309
	100	36	60,5	50	6	1,55	2309 E-2RS1KTN9	H 2309

▶ Popular item

¹⁾ For additional bearing data → [product table, page 450](#)

²⁾ For additional adapter sleeve data → [product table, page 1072](#)

Principal dimensions			Abutment and fillet dimensions			Mass Bearing + sleeve	Designations Bearing ¹⁾	Sleeve ²⁾	
d	D	B	d _a max.	d _b min.	B _a min.				
mm			mm			kg	–		
45	90	20	62	53	6	0,77	▶ 1210 EKTN9 2210 E-2RS1KTN9 2210 EKTN9	H 210 H 310 E H 310	
	90	23	58	55	10	0,84			
	90	23	61	55	10	0,87			
		110	27	70	55	6	1,45	▶ 1310 EKTN9 2310 E-2RS1KTN9 2310 K	H 310 H 2310 H 2310
		110	40	62,5	56	6	2		
		110	40	65	56	6	1,9		
50	100	21	70	60	7	0,99	▶ 1211 EKTN9 2211 E-2RS1KTN9 2211 EKTN9	H 211 H 311 E H 311	
	100	25	65,5	60	11	1,1			
	100	25	67	60	11	1,15			
		120	29	77	60	7	1,9	▶ 1311 EKTN9 2311 K	H 311 H 2311
		120	43	72	61	7	2,4		
	55	110	22	78	64	7	1,2	▶ 1212 EKTN9 2212 E-2RS1KTN9 2212 EKTN9	H 212 H 312 E H 312
110		28	73	65	9	1,4			
110		28	74	65	9	1,45			
		130	31	87	65	7	2,15	▶ 1312 EKTN9 2312 K	H 312 H 2312
		130	46	76	66	7	2,95		
60		120	23	85	70	7	1,45	▶ 1213 EKTN9 2213 E-2RS1KTN9 2213 EKTN9	H 213 H 313 E H 313
	120	31	79	70	7	1,75			
	120	31	80	70	9	1,8			
		140	33	98	70	7	2,85	▶ 1313 EKTN9 2313 K	H 313 H 2313
		140	48	85	72	7	3,6		
	65	130	25	93	80	7	2	▶ 1215 K 2215 EKTN9	H 215 H 315
130		31	93	80	13	2,3			
		160	37	104	80	7	4,2		
		160	55	97	82	7	5,55	▶ 1315 K 2315 K	H 315 H 2315
70		140	26	101	85	7	2,4	▶ 1216 K 2216 EKTN9	H 216 H 316
		140	33	99	85	13	2,85		
		170	39	109	85	7	5		
		170	58	104	88	7	7,1	▶ 1316 K 2316 K	H 316 H 2316
	75	150	28	107	90	8	2,95	▶ 1217 K 2217 K	H 217 H 317
		150	36	105	91	13	3,3		
		180	41	117	91	8	6		
80		160	30	112	95	8	3,5	▶ 1218 K 2218 K	H 218 H 318
		160	40	112	96	11	5,5		
			190	43	122	96	8		
		190	64	115	100	8	9,8	▶ 1318 K 2318 K	H 318 H 2318
	85	170	32	120	100	8	4,25	▶ 1219 K 2219 K	H 219 H 319
		170	43	118	102	10	5,3		
		200	45	127	102	8	7,9		
		200	67	128	105	8	11,5	▶ 1319 K 2319 KM	H 319 H 2319
90		180	34	127	106	8	5	▶ 1220 K 2220 K	H 220 H 320
		180	46	124	108	9	6,4		
		215	47	136	108	8	9,65		
		215	73	130	110	8	14	▶ 1320 K 2320 K	H 320 H 2320

▶ Popular item

¹⁾ For additional bearing data → [product table, page 450](#)

²⁾ For additional adapter sleeve data → [product table, page 1072](#)



4.2 Self-aligning ball bearings on an adapter sleeve

d 100 – 115 mm

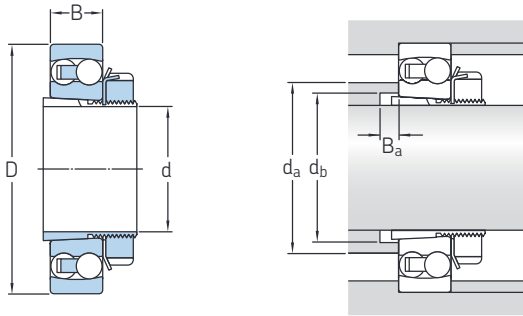

4.2

Principal dimensions			Abutment and fillet dimensions			Mass Bearing + sleeve	Designations Bearing ¹⁾	Sleeve ²⁾
d	D	B	d _a max.	d _b min.	B _a min.			
mm			mm			kg	–	
100	200	38	140	116	8	6,8	▶ 1222 K	H 222
	200	53	137	118	8	8,85	2222 K	H 322
	240	50	154	118	10	13,5	1322 KM	H 322
110	215	42	150	127	12	8,3	1224 KM	H 3024
115	230	46	163	137	15	11	1226 KM	H 3026

▶ Popular item

¹⁾ For additional bearing data → [product table, page 450](#)

²⁾ For additional adapter sleeve data → [product table, page 1072](#)



4.3 Self-aligning ball bearings with an extended inner ring

d 20 – 60 mm

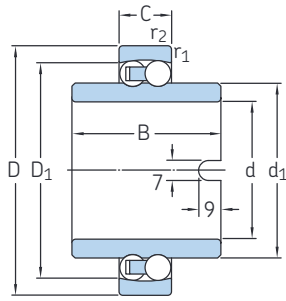

4.3

Principal dimensions			Basic load ratings		Fatigue load limit	Limiting speed	Mass	Designation
d	D	C	dynamic	static				
			C	C_0	P_u			
mm			kN		kN	r/min	kg	–
20	47	14	12,7	3,4	0,18	9 000	0,18	11204 ETN9
25	52	15	14,3	4	0,21	8 000	0,22	11205 ETN9
30	62	16	15,6	4,65	0,24	6 700	0,35	11206 TN9
35	72	17	19	6	0,305	5 600	0,54	11207 TN9
40	80	18	19	6,55	0,335	5 000	0,72	11208 TN9
45	85	19	22,9	7,8	0,4	4 500	0,77	11209 TN9
50	90	20	26,5	9,15	0,475	4 300	0,85	11210 TN9
60	110	22	31,2	12,2	0,62	3 400	1,15	11212 TN9

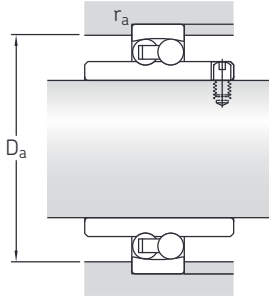

Dimensions					Abutment and fillet dimensions		Calculation factors				
d	d ₁ ≈	D ₁ ≈	B	r _{1,2} min.	D _a max.	r _a max.	k _r	e	Y ₁	Y ₂	Y ₀
mm					mm		-				
20	28,8	40	40	1	41,4	1	0,04	0,3	2,1	3,3	2,2
25	33,3	44,6	44	1	46,4	1	0,04	0,28	2,2	3,5	2,5
30	40,1	51,9	48	1	56,4	1	0,04	0,25	2,5	3,9	2,5
35	47	60,9	52	1,1	65	1,1	0,04	0,23	2,7	4,2	2,8
40	54	67,5	56	1,1	73	1,1	0,04	0,22	2,9	4,5	2,8
45	57,7	72,5	58	1,1	78	1,1	0,04	0,21	3	4,6	3,2
50	61,7	78,1	58	1,1	83	1,1	0,04	0,21	3	4,6	3,2
60	78	95,6	62	1,5	101	1,5	0,04	0,19	3,3	5,1	3,6