

FAG



Double Row Angular Contact Ball Bearings

X-life quality

SCHAEFFLER

Double row angular contact ball bearings

	Page
Product overview	Double row angular contact ball bearings 2
Features	X-life..... 3
	Radial and axial load carrying capacity 4
	Without filling slot 4
	Sealing 4
	Lubrication 4
	Operating temperature..... 5
	Cages 5
	Suffixes 6
Design and safety guidelines	Equivalent dynamic bearing load 7
	Equivalent static bearing load 7
	Minimum radial load..... 7
	Speeds 7
	Design of bearing arrangements..... 8
Accuracy	Axial internal clearance..... 10
Dimension tables	Angular contact ball bearings, double row, open or sealed..... 12

Product overview Double row angular contact ball bearings

Double row

32...-BD, 33...-BD

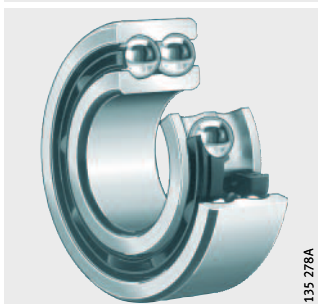

32...-BD, 33...-BD



Lip seals or gap seals

32...-BD-2HRS, 33...-BD-2HRS

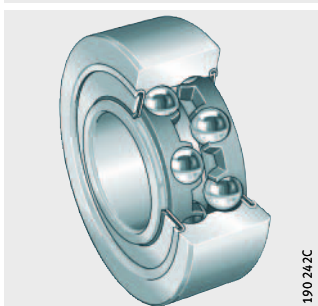

32...-BD-2Z, 33...-BD-2Z

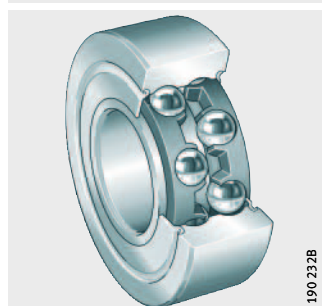

Double row angular contact ball bearings

Features Double row angular contact ball bearings are units with solid inner and outer rings and ball and cage assemblies with polyamide or sheet steel cages. Their construction is similar to a pair of single row angular contact ball bearings in an O arrangement but they are narrower to a certain extent.

The bearings are available in open and sealed designs. Due to the manufacturing processes used, open bearings can have turned recesses in the outer ring for seals or shields. Sealed bearings are maintenance-free and therefore allow particularly economical bearing arrangements.

Due to the raceway geometry and the two rows of balls, the bearing can support forces in both radial and axial directions. They are therefore particularly suitable for use in pumps and agricultural machinery. Furthermore, double row angular contact ball bearings are used in applications including conveying equipment, packaging equipment, elevators and compressors.

The angular adjustment facility of angular contact ball bearings is very limited. The adjustment angle should not exceed 2°.

X-life Bearings of X-life quality have improved running accuracy and optimised surfaces. This gives a significant increase in the fatigue limit load of the bearings. In terms of the expanded adjusted rating life, values up to 50% are achieved. In certain applications, this means that a smaller bearing arrangement can be designed.

Lower noise levels Due to the higher ball quality, improved raceway surfaces and the more precise dimensional and running tolerances to tolerance class P6, the internal friction in the bearings as well as the noise level of the application during operation is reduced.

Reduced friction Lower friction leads to reduced heat generation and thus a longer grease operating life. As a result, higher speeds or an extended operating life of the bearing can be achieved. In addition, this increases the energy efficiency of the application.

Improved sealing The innovative seal HRS is in axial contact with the inner ring in an undercut. It thus offers the optimum combination of maximum sealing effectiveness and minimal friction.

Higher cost-effectiveness Overall, these measures lead to greater economic benefit for the user. Double row angular contact ball bearings of X-life quality offer a longer operating life, especially in use under axial load conditions. The maintenance intervals in the specific applications can thus be extended. Due to the reduced friction, savings on energy consumption and operating costs can be achieved.

Double row angular contact ball bearings

Radial and axial load carrying capacity

Double row angular contact ball bearings can support axial loads in both directions and high radial loads. They are particularly suitable for bearing arrangements where rigid axial guidance is required.

The axial load carrying capacity is dependent on the contact angle; i.e. the larger the angle ($\alpha = 30^\circ$), the higher the axial load to which the bearing can be subjected.

Without filling slot

Bearings of series 32...-BD and 33...-BD are self-retaining and do not have filling slots in the end faces of the bearing rings. The contact angle is $\alpha = 30^\circ$. Their axial load carrying capacity is the same in both directions. These bearings are highly versatile.

Sealing

Series 32...-BD and 33...-BD with the suffixes 2HRS are sealed by lip seals on both sides. Contact seals are suitable for giving protection against dust, contamination and damp atmospheres. The new design of lip geometry, with axial contact and a dust deflector, has lower friction and thus generates less heat. This allows higher speeds.

Series with the suffix 2Z have gap seals of a labyrinth design on both sides. The undercuts and the sealing shield geometry are matched to each other.

Both sealing systems 2Z and 2HRS offer reliable protection against the egress of grease from the bearing and the ingress of contamination into the bearing.

- ① Open bearing
- ② Gap seals on both sides (2Z)
- ③ Lip seals on both sides (2HRS)

Figure 1
Available designs

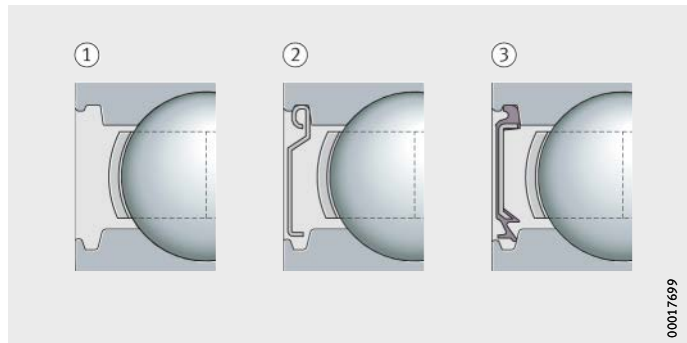

Lubrication

Sealed bearings are greased with a high quality grease and are lubricated for life. Open bearings are preserved using oil. In addition to the standard grease, special greases are also available by agreement for particular operating conditions.

Operating temperature

Open bearings are suitable, depending on their outside diameter, for different operating temperature ranges. Bearings are available by agreement for temperatures up to +200 °C. For standard bearings, see table.

Operating temperature ranges

Outside diameter mm	Operating temperature °C
≤ 90	-30 to +120
> 90	-30 to +150



Bearings with cages made from glass fibre reinforced polyamide are suitable for operating temperatures up to +120 °C, restricted by the cage material.

Bearings with the suffix 2HRS are suitable up to +110 °C, restricted by the lubricant and seal material.

Cages

Bearings without a cage suffix have standard cages made from sheet steel.

The new sheet steel cages are of an optimised design and are suitable for temperatures up to +200 °C. They are therefore more rigid and thus more robust and generate less operating noise. The grease is distributed better and the bearing operating life is extended. Upon customer request, steel cages can be made more resistant to chemical fluids by means of coatings and special heat treatments.

Angular contact ball bearings with cages made from glass fibre reinforced polyamide have the suffix TVH.

The revised polyamide cages were optimised on the basis of objectives similar to those for the steel cages: higher rigidity, better grease distribution, reduced energy consumption and thus lower generation of heat and noise. This allows higher speeds as well as a longer grease and bearing operating life.

Available standard designs, see table.

Cage and bore code

Series	Polyamide cage ¹⁾	Sheet steel cage ¹⁾
	Bore code	
32..-BD	02 to 13	02 to 13
33..-BD	02 to 11	04 to 11

¹⁾ Other cage designs are available by agreement. In such cages, suitability for high speeds and temperatures as well as the basic load ratings may differ from the values for bearings with standard cages.



Check the chemical resistance of the polyamide to synthetic greases and lubricants with EP additives.

Aged oil and additives in the oil can impair the operating life of plastic cages at high temperatures.

The oil change intervals must be observed.

Double row angular contact ball bearings

Oil changes At temperatures in the bearing of less than +50 °C and with only slight contamination, an oil change once per year is generally sufficient.



Guide values for oil change intervals are given in *Figure 2*.
The precise oil change intervals should be agreed in consultation with the oil manufacturer.

ϑ = oil sump temperature
t = oil change interval

① Synthetic gearbox oils
② Mineral gearbox oils

Source: FVA Project No. 171

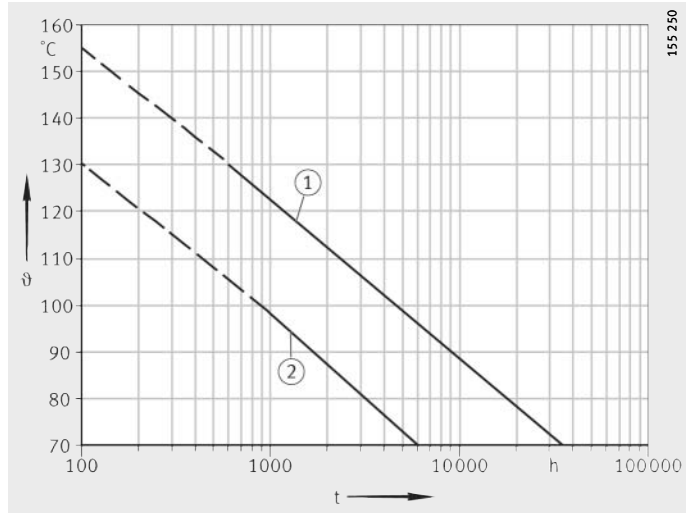

Figure 2
Oil change intervals

Suffixes Suffixes for available designs: see table.

Available designs

Suffix	Description	Design
BD	Modified internal construction, contact angle $\alpha = 30^\circ$, without filling slot	Standard
TVH	Solid polyamide snap cage, ball-guided	
2HRS	Lip seals on both sides	
2Z	Gap seals on both sides	
C2	Axial internal clearance C2	Special design, available by agreement
C3	Axial internal clearance C3	
C4	Axial internal clearance C4	
RROC	Corrotect® coating	
S0	Dimensional stabilisation	
S1	Dimensional stabilisation	

Design and safety guidelines

Equivalent dynamic bearing load

The equivalent dynamic bearing load P is valid for bearings that are subjected to radial and axial dynamic loads. It gives the same rating life as the combined bearing load occurring in practice.

For bearings under dynamic loading, the following applies:

Contact angle 30°

Load ratio	Equivalent dynamic bearing load
$\frac{F_a}{F_r} \leq 0,8$	$P = F_r + 0,78 \cdot F_a$
$\frac{F_a}{F_r} > 0,8$	$P = 0,63 \cdot F_r + 1,24 \cdot F_a$

F_a N
Axial dynamic bearing load
 F_r N
Radial dynamic bearing load
 P N
Equivalent dynamic bearing load for combined load.

Equivalent static bearing load

The equivalent static bearing load for combined loads P_0 is valid for bearings that are subjected to radial and axial static loads.

It induces the same load at the centre point of the most heavily loaded contact point between the rolling element and raceway as the combined bearing load occurring in practice.

Contact angle 30°

For bearings under static loading, the following applies:

$$P_0 = F_{0r} + 0,66 \cdot F_{0a}$$

P_0 N
Equivalent static bearing load for combined load
 F_{0a} N
Axial static bearing load
 F_{0r} N
Radial static bearing load.

Minimum radial load

In order to ensure slippage-free operation, the bearings must be subjected to a minimum radial load. This applies particularly in the case of high speeds and high accelerations. In continuous operation, a minimum radial load of the order of $P/C_r > 0,01$ is necessary for ball bearings with cage.

Speeds

The reference speed n_B can be exceeded up to the limiting speed n_G if permitted by the operating conditions. If the reference speed in the tables is higher than the limiting speed, the higher value cannot be used.

In bearings with lip seals 2HRS, the speed is limited by the permissible sliding speed of the sealing lips, so only the limiting speed is given in the dimension tables.



The limiting speed n_G given in the dimension tables must not be exceeded.

Double row angular contact ball bearings

Design of bearing arrangements

In order to make comprehensive use of the performance capacity of the bearings, the adjacent construction must be of an appropriate design.

Shaft and housing tolerances

The recommended shaft tolerances for radial bearings with a cylindrical bore must be observed, see table.

The recommended housing tolerances for radial bearings must be observed, see table, page 9.

Shaft tolerances for radial bearings with cylindrical bore

Conditions of rotation	Bearing type	Shaft diameter mm	Displacement capability, load	Tolerance zone
Point load on inner ring	Ball bearings, roller bearings	All sizes	Inner ring easily displaced	g6 (g5)
			Inner ring not easily displaced	h6 (j6)
			Angular contact ball bearings and tapered roller bearings with adjusted inner ring	
Circumferential load on inner ring or indeterminate load direction	Ball bearings	up to 50	Normal loads ²⁾	j6 (j5)
		50 to 100	Low loads ³⁾	j6 (j5)
			Normal and high loads ⁴⁾	k6 (k5)
		100 to 200	Low loads ²⁾	k6 (m6)
			Normal and high loads ⁵⁾	m6 (m5)
		over 200	Low loads	m6 (m5)
Normal and high loads	n6 (n5)			

1) For easier fitting.

2) $C/P > 10$.

3) $C/P > 12$.

4) $C/P < 12$.

5) $C/P < 10$.

Housing tolerances for radial bearings

Conditions of rotation	Displacement capability, load	Operating conditions	Tolerance zone
Point load on outer ring	Outer ring easily displaced, housing unsplit	The tolerance grade is determined by the running accuracy required	H7 (H6) ¹⁾
	Outer ring easily displaced, housing split		H8 (H7)
	Outer ring not easily displaced, housing unsplit	High running accuracy required	H6 (J6)
	Outer ring not easily displaced, angular contact ball bearings and tapered roller bearings with adjusted outer ring, housing split	Normal running accuracy	H7 (J7)
	Outer ring easily displaced	Heat input via shaft	G7 ²⁾
Circumferential load on outer ring or indeterminate load direction	Low loads, outer ring cannot be displaced	With high requirements for running accuracy K6, M6, N6 and P6	K7 (K6)
	Normal loads, shocks, outer ring cannot be displaced		M7 (M6)
	High loads, shocks ($C/P < 6$), outer ring cannot be displaced		N7 (N6)
	High loads, severe shocks, thin-walled housing, outer ring cannot be displaced		P7 (P6)

1) G7 for housings made from GG, if bearing outside diameter $D > 250$ mm and temperature difference between outer ring and housing > 10 K.

2) F7 for housings made from GG, if bearing outside diameter $D > 250$ mm and temperature difference between outer ring and housing > 10 K.

Mounting dimensions

The dimension tables give the maximum dimension of the radius r_a and the diameters of the abutment shoulders D_a and d_a .

Double row angular contact ball bearings

Accuracy The main dimensions of the bearings conform to DIN 628-3. The dimensional and geometrical tolerances of the bearings correspond to tolerance class P6 to DIN 620-2.

Axial internal clearance Double row angular contact ball bearings of the basic design have the normal axial internal clearance (CN), see table. Bearings are available by agreement with a larger (C3, C4) or smaller (C2) axial internal clearance.

Axial internal clearance to DIN 628-3 for bearings with unsplit inner ring

Bore d mm		Axial internal clearance							
		C2 μm		CN μm		C3 μm		C4 μm	
over	incl.	min.	max.	min.	max.	min.	max.	min.	max.
–	10	1	11	5	21	12	28	25	45
10	18	1	12	6	23	13	31	27	47
18	24	2	14	7	25	16	34	27	47
24	30	2	15	8	27	18	37	30	50
30	40	2	16	9	29	21	40	33	54
40	50	2	18	11	33	23	44	36	58
50	65	3	22	13	36	26	48	40	63
65	80	3	24	15	40	30	54	46	71
80	100	3	26	18	46	35	63	55	83
100	120	4	30	22	53	42	73	65	96
120	140	4	34	25	59	48	82	74	108

Angular contact ball bearings

Double row
Open or sealed

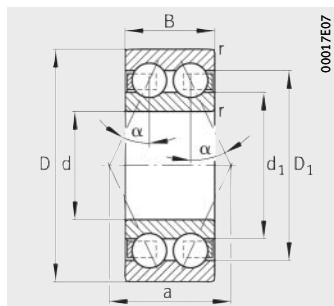

32..-BD, 33..-BD
 $\alpha = 30^\circ$

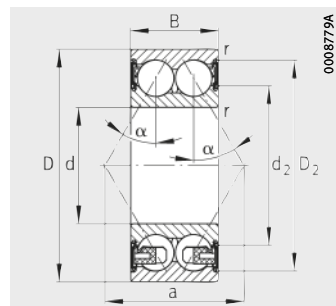

32..-BD-2HRS, 33..-BD-2HRS
 $\alpha = 30^\circ$

Dimension table · Dimensions in mm

Designation			Mass m ≈ kg	Dimensions					
Series 32	Series 33	X-life		d	D	B	r min.	D ₁ ≈	D ₂ ≈
3202-BD	–	XL	0,065	15	35	15,9	0,6	29,4	–
3202-BD-TVH	–	XL	0,066	15	35	15,9	0,6	29,4	–
3202-BD-2HRS	–	XL	0,068	15	35	15,9	0,6	–	31,1
3202-BD-2HRS-TVH	–	XL	0,065	15	35	15,9	0,6	–	31,1
3202-BD-2Z	–	XL	0,068	15	35	15,9	0,6	–	31,1
3202-BD-2Z-TVH	–	XL	0,065	15	35	15,9	0,6	–	31,1
–	3302-BD-TVH	XL	0,124	15	42	19	1	35,7	–
–	3302-BD-2HRS-TVH	XL	0,122	15	42	19	1	–	37,9
–	3302-BD-2Z-TVH	XL	0,122	15	42	19	1	–	37,9
3203-BD	–	XL	0,094	17	40	17,5	0,6	33,9	–
3203-BD-TVH	–	XL	0,095	17	40	17,5	0,6	33,9	–
3203-BD-2HRS	–	XL	0,098	17	40	17,5	0,6	–	36,1
3203-BD-2HRS-TVH	–	XL	0,093	17	40	17,5	0,6	–	36,1
3203-BD-2Z	–	XL	0,098	17	40	17,5	0,6	–	36,1
3203-BD-2Z-TVH	–	XL	0,094	17	40	17,5	0,6	–	36,1
–	3303-BD-TVH	XL	0,177	17	47	22,2	1	39	–
–	3303-BD-2HRS-TVH	XL	0,176	17	47	22,2	1	–	41,1
–	3303-BD-2Z-TVH	XL	0,176	17	47	22,2	1	–	41,1
3204-BD	–	XL	0,153	20	47	20,6	1	40,1	–
3204-BD-TVH	–	XL	0,154	20	47	20,6	1	40,1	–
3204-BD-2HRS	–	XL	0,157	20	47	20,6	1	–	42,2
3204-BD-2HRS-TVH	–	XL	0,149	20	47	20,6	1	–	42,2
3204-BD-2Z	–	XL	0,157	20	47	20,6	1	–	42,2
3204-BD-2Z-TVH	–	XL	0,153	20	47	20,6	1	–	42,2
–	3304-BD	XL	0,217	20	52	22,2	1,1	44	–
–	3304-BD-TVH	XL	0,215	20	52	22,2	1,1	44	–
–	3304-BD-2HRS	XL	0,223	20	52	22,2	1,1	–	46,1
–	3304-BD-2HRS-TVH	XL	0,217	20	52	22,2	1,1	–	46,1
–	3304-BD-2Z	XL	0,222	20	52	22,2	1,1	–	46,1
–	3304-BD-2Z-TVH	XL	0,214	20	52	22,2	1,1	–	46,1

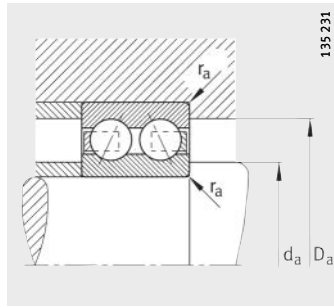
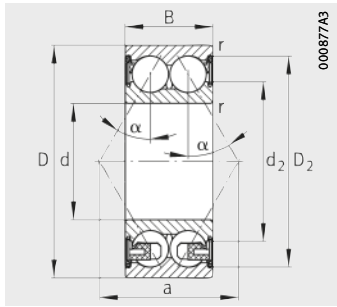

32..-BD-2Z, 33..-BD-2Z
 $\alpha = 30^\circ$

Mounting dimensions

			Mounting dimensions			Basic load ratings		Fatigue limit load C_{ur} N	Limiting speed n_G min^{-1}	Reference speed n_B min^{-1}
d_1 \approx	d_2 \approx	a \approx	d_a min.	D_a max.	r_a max.	dyn. C_r N	stat. C_{0r} N			
22,2	–	20,7	19,2	30,8	0,6	12 600	7 400	500	22 300	18 500
22,2	–	20,7	19,2	30,8	0,6	12 600	7 400	500	22 300	18 500
–	21	20,7	19,2	30,8	0,6	12 600	7 400	500	16 700	–
–	21	20,7	19,2	30,8	0,6	12 600	7 400	500	16 700	–
–	21	20,7	19,2	30,8	0,6	12 600	7 400	500	16 700	18 500
–	21	20,7	19,2	30,8	0,6	12 600	7 400	500	16 700	18 500
27,2	–	24,8	20,6	36,4	1	17 000	10 400	700	18 400	13 200
–	25,8	24,8	20,6	36,4	1	17 000	10 400	700	13 800	–
–	25,8	24,8	20,6	36,4	1	17 000	10 400	700	13 800	13 200
25,8	–	23,5	21,2	35,8	0,6	15 500	9 500	640	19 400	16 600
25,8	–	23,5	21,2	35,8	0,6	15 500	9 500	640	19 400	16 600
–	24,4	23,5	21,2	35,8	0,6	15 500	9 500	640	14 600	–
–	24,4	23,5	21,2	35,8	0,6	15 500	9 500	640	14 600	–
–	24,4	23,5	21,2	35,8	0,6	15 500	9 500	640	14 600	16 600
–	24,4	23,5	21,2	35,8	0,6	15 500	9 500	640	14 600	16 600
28,5	–	27,5	22,6	41,4	1	22 500	13 100	880	16 600	12 600
–	27,1	27,5	22,6	41,4	1	22 500	13 100	880	12 400	–
–	27,1	27,5	22,6	41,4	1	22 500	13 100	880	12 400	12 600
30,8	–	27,9	25,6	41,4	1	20 600	12 900	870	16 100	15 000
30,8	–	27,9	25,6	41,4	1	20 600	12 900	870	16 100	15 000
–	29,2	27,9	25,6	41,4	1	20 600	12 900	870	12 100	–
–	29,2	27,9	25,6	41,4	1	20 600	12 900	870	12 100	–
–	29,2	27,9	25,6	41,4	1	20 600	12 900	870	12 100	15 000
–	29,2	27,9	25,6	41,4	1	20 600	12 900	870	12 100	15 000
33,5	–	30,4	27	45	1	24 600	15 900	1 070	14 700	10 900
33,5	–	30,4	27	45	1	24 600	15 900	1 070	14 700	10 900
–	31,9	30,4	27	45	1	24 600	15 900	1 070	11 000	–
–	31,9	30,4	27	45	1	24 600	15 900	1 070	11 000	–
–	31,9	30,4	27	45	1	24 600	15 900	1 070	11 000	10 900
–	31,9	30,4	27	45	1	24 600	15 900	1 070	11 000	10 900

Angular contact ball bearings

Double row
Open or sealed

X-life

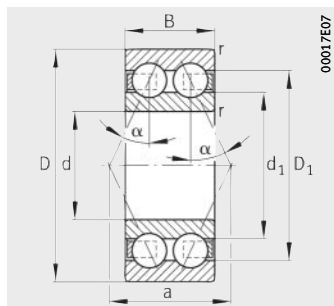

32...-BD, 33...-BD
 $\alpha = 30^\circ$

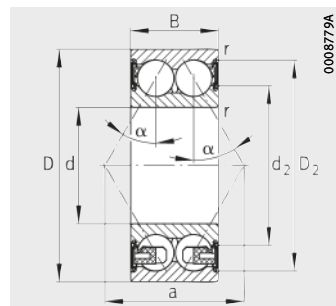

32...-BD-2HRS, 33...-BD-2HRS
 $\alpha = 30^\circ$

Dimension table (continued) · Dimensions in mm

Designation			Mass m ≈ kg	Dimensions					
Series 32	Series 33	X-life		d	D	B	r min.	D ₁ ≈	D ₂ ≈
3205-BD	–	XL	0,175	25	52	20,6	1	45,1	–
3205-BD-TVH	–	XL	0,174	25	52	20,6	1	45,1	–
3205-BD-2HRS	–	XL	0,18	25	52	20,6	1	–	47,6
3205-BD-2HRS-TVH	–	XL	0,176	25	52	20,6	1	–	47,6
3205-BD-2Z	–	XL	0,18	25	52	20,6	1	–	47,6
3205-BD-2Z-TVH	–	XL	0,175	25	52	20,6	1	–	47,6
–	3305-BD	XL	0,355	25	62	25,4	1,1	51,5	–
–	3305-BD-TVH	XL	0,352	25	62	25,4	1,1	51,5	–
–	3305-BD-2HRS	XL	0,36	25	62	25,4	1,1	–	53,7
–	3305-BD-2HRS-TVH	XL	0,352	25	62	25,4	1,1	–	53,7
–	3305-BD-2Z	XL	0,361	25	62	25,4	1,1	–	53,7
–	3305-BD-2Z-TVH	XL	0,348	25	62	25,4	1,1	–	53,7
3206-BD	–	XL	0,292	30	62	23,8	1	53,3	–
3206-BD-TVH	–	XL	0,288	30	62	23,8	1	53,3	–
3206-BD-2HRS	–	XL	0,3	30	62	23,8	1	–	55,8
3206-BD-2HRS-TVH	–	XL	0,29	30	62	23,8	1	–	55,8
3206-BD-2Z	–	XL	0,3	30	62	23,8	1	–	55,8
3206-BD-2Z-TVH	–	XL	0,283	30	62	23,8	1	–	55,8
–	3306-BD	XL	0,56	30	72	30,2	1,1	60,5	–
–	3306-BD-TVH	XL	0,543	30	72	30,2	1,1	60,5	–
–	3306-BD-2HRS	XL	0,56	30	72	30,2	1,1	–	63,5
–	3306-BD-2HRS-TVH	XL	0,549	30	72	30,2	1,1	–	63,5
–	3306-BD-2Z	XL	0,559	30	72	30,2	1,1	–	63,5
–	3306-BD-2Z-TVH	XL	0,54	30	72	30,2	1,1	–	63,5

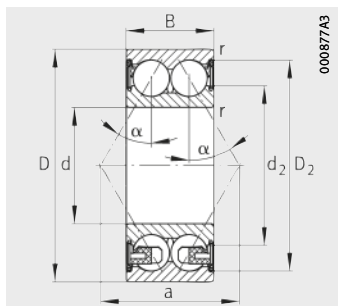

32..-BD-2Z, 33..-BD-2Z
 $\alpha = 30^\circ$

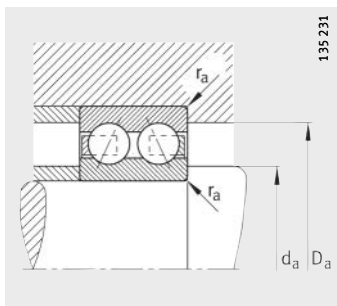

Mounting dimensions

			Mounting dimensions			Basic load ratings		Fatigue limit load C_{ur} N	Limiting speed n_G min^{-1}	Reference speed n_B min^{-1}
d_1 \approx	d_2 \approx	a \approx	d_a min.	D_a max.	r_a max.	dyn. C_r N	stat. C_{0r} N			
35,8	–	30,8	30,6	46,4	1	22 000	15 200	1 020	14 300	12 700
35,8	–	30,8	30,6	46,4	1	22 000	15 200	1 020	14 300	12 700
–	34,2	30,8	30,6	46,4	1	22 000	15 200	1 020	10 700	–
–	34,2	30,8	30,6	46,4	1	22 000	15 200	1 020	10 700	–
–	34,2	30,8	30,6	46,4	1	22 000	15 200	1 020	10 700	12 700
–	34,2	30,8	30,6	46,4	1	22 000	15 200	1 020	10 700	12 700
39,5	–	35,4	32	55	1	31 500	21 000	1 410	12 400	9 400
39,5	–	35,4	32	55	1	31 500	21 000	1 410	12 400	9 400
–	37,6	35,4	32	55	1	31 500	21 000	1 410	9 300	–
–	37,6	35,4	32	55	1	31 500	21 000	1 410	9 300	–
–	37,6	35,4	32	55	1	31 500	21 000	1 410	9 300	9 400
–	37,6	35,4	32	55	1	31 500	21 000	1 410	9 300	9 400
42,2	–	36,4	35,6	56,4	1	31 000	22 200	1 490	11 900	11 100
42,2	–	36,4	35,6	56,4	1	31 000	22 200	1 490	11 900	11 100
–	40,3	36,4	35,6	56,4	1	31 000	22 200	1 490	9 000	–
–	40,3	36,4	35,6	56,4	1	31 000	22 200	1 990	9 000	–
–	40,3	36,4	35,6	56,4	1	31 000	22 200	1 990	9 000	11 100
–	40,3	36,4	35,6	56,4	1	31 000	22 200	1 490	9 000	11 100
46,3	–	41,9	37	65	1	43 000	29 500	1 990	10 400	8 500
46,3	–	41,9	37	65	1	43 000	29 500	1 990	10 400	8 500
–	44,4	41,9	37	65	1	43 000	29 500	1 990	7 800	–
–	44,4	41,9	37	65	1	43 000	29 500	1 990	7 800	–
–	44,4	41,9	37	65	1	43 000	29 500	1 990	7 800	8 500
–	44,4	41,9	37	65	1	43 000	29 500	1 990	7 800	8 500

Angular contact ball bearings

Double row
Open or sealed

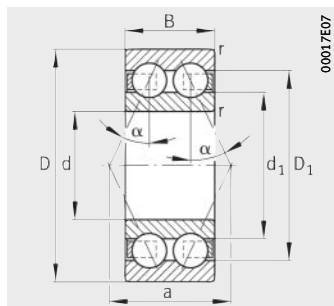

32...-BD, 33...-BD
 $\alpha = 30^\circ$

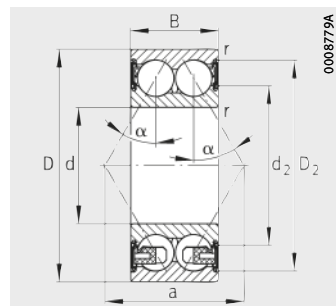

32...-BD-2HRS, 33...-BD-2HRS
 $\alpha = 30^\circ$

Dimension table (continued) · Dimensions in mm

Designation			Mass m ≈ kg	Dimensions					
Series 32	Series 33	X-life		d	D	B	r min.	D ₁ ≈	D ₂ ≈
3207-BD	–	XL	0,44	35	72	27	1,1	62,4	–
3207-BD-TVH	–	XL	0,436	35	72	27	1,1	62,4	–
3207-BD-2HRS	–	XL	0,45	35	72	27	1,1	–	65,4
3207-BD-2HRS-TVH	–	XL	0,44	35	72	27	1,1	–	65,4
3207-BD-2Z	–	XL	0,45	35	72	27	1,1	–	65,4
3207-BD-2Z-TVH	–	XL	0,432	35	72	27	1,1	–	65,4
–	3307-BD	XL	0,73	35	80	34,9	1,5	68,9	–
–	3307-BD-TVH	XL	0,706	35	80	34,9	1,5	68,9	–
–	3307-BD-2HRS	XL	0,74	35	80	34,9	1,5	–	71,9
–	3307-BD-2HRS-TVH	XL	0,717	35	80	34,9	1,5	–	71,9
–	3307-BD-2Z	XL	0,736	35	80	34,9	1,5	–	71,9
–	3307-BD-2Z-TVH	XL	0,702	35	80	34,9	1,5	–	71,9
3208-BD	–	XL	0,59	40	80	30,2	1,1	69,6	–
3208-BD-TVH	–	XL	0,591	40	80	30,2	1,1	69,6	–
3208-BD-2HRS	–	XL	0,6	40	80	30,2	1,1	–	72,6
3208-BD-2HRS-TVH	–	XL	0,597	40	80	30,2	1,1	–	72,6
3208-BD-2Z	–	XL	0,605	40	80	30,2	1,1	–	72,6
3208-BD-2Z-TVH	–	XL	0,58	40	80	30,2	1,1	–	72,6
–	3308-BD	XL	0,99	40	90	36,5	1,5	77	–
–	3308-BD-TVH	XL	0,969	40	90	36,5	1,5	77	–
–	3308-BD-2HRS	XL	1,01	40	90	36,5	1,5	–	79,9
–	3308-BD-2HRS-TVH	XL	0,985	40	90	36,5	1,5	–	79,9
–	3308-BD-2Z	XL	1,008	40	90	36,5	1,5	–	79,9
–	3308-BD-2Z-TVH	XL	0,967	40	90	36,5	1,5	–	79,9

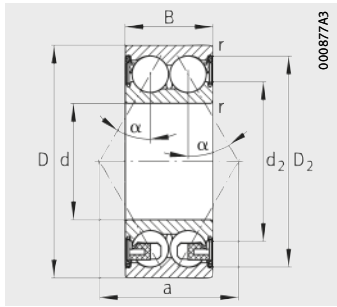

32..-BD-2Z, 33..-BD-2Z
 $\alpha = 30^\circ$

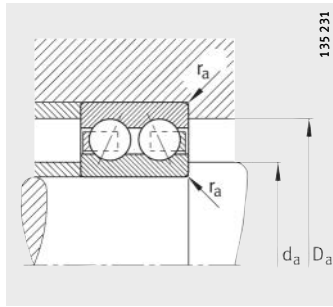

Mounting dimensions

			Mounting dimensions			Basic load ratings		Fatigue limit load C_{ur} N	Limiting speed n_G min^{-1}	Reference speed n_B min^{-1}
d_1 \approx	d_2 \approx	a \approx	d_a min.	D_a max.	r_a max.	dyn. C_r N	stat. C_{0r} N			
49,1	–	42,5	42	65	1	41 000	30 000	2 030	10 100	9 900
49,1	–	42,5	42	65	1	41 000	30 000	2 030	10 100	9 900
–	46,9	42,5	42	65	1	41 000	30 000	2 030	7 500	–
–	46,9	42,5	42	65	1	41 000	30 000	2 030	7 600	–
–	46,9	42,5	42	65	1	41 000	30 000	2 030	7 500	9 800
–	46,9	42,5	42	65	1	41 000	30 000	2 030	7 600	9 900
51,8	–	48	44	71	1,5	55 000	36 500	2 460	9 000	8 100
51,8	–	48	44	71	1,5	55 000	36 500	2 460	9 000	8 100
–	49,6	48	44	71	1,5	55 000	36 500	2 460	6 800	–
–	49,6	48	44	71	1,5	55 000	36 500	2 460	6 800	–
–	49,6	48	44	71	1,5	55 000	36 500	2 460	6 800	8 100
–	49,6	48	44	71	1,5	55 000	36 500	2 460	6 800	8 100
54,9	–	47,4	47	73	1	51 000	38 000	2 550	8 900	9 100
54,9	–	47,4	47	73	1	51 000	38 000	2 550	8 900	9 100
–	52,8	47,4	47	73	1	51 000	38 000	2 550	6 700	–
–	52,8	47,4	47	73	1	51 000	38 000	2 550	6 700	–
–	52,8	47,4	47	73	1	51 000	38 000	2 550	6 700	9 100
–	52,8	47,4	47	73	1	51 000	38 000	2 550	6 700	9 100
59	–	53,1	49	81	1,5	67 000	48 500	3 250	8 000	7 000
59	–	53,1	49	81	1,5	67 000	48 500	3 250	8 000	7 000
–	56,8	53,1	49	81	1,5	67 000	48 500	3 250	6 000	–
–	56,8	53,1	49	81	1,5	67 000	48 500	3 250	6 000	–
–	56,8	53,1	49	81	1,5	67 000	48 500	3 250	6 000	7 000
–	56,8	53,1	49	81	1,5	67 000	48 500	3 250	6 000	7 000

Angular contact ball bearings

Double row
Open or sealed

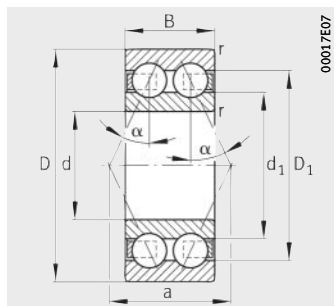

32...-BD, 33...-BD
 $\alpha = 30^\circ$

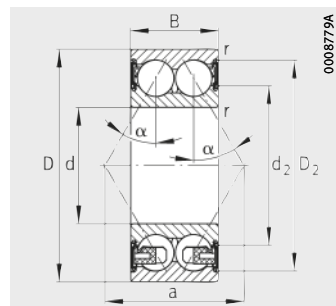

32...-BD-2HRS, 33...-BD-2HRS
 $\alpha = 30^\circ$

Dimension table (continued) · Dimensions in mm

Designation			Mass m ≈ kg	Dimensions					
Series 32	Series 33	X-life		d	D	B	r min.	D ₁ ≈	D ₂ ≈
3209-BD	–	XL	0,622	45	85	30,2	1,1	75,1	–
3209-BD-TVH	–	XL	0,622	45	85	30,2	1,1	75,1	–
3209-BD-2HRS	–	XL	0,644	45	85	30,2	1,1	–	78,1
3209-BD-2HRS-TVH	–	XL	0,626	45	85	30,2	1,1	–	78,1
3209-BD-2Z	–	XL	0,64	45	85	30,2	1,1	–	78,1
3209-BD-2Z-TVH	–	XL	0,618	45	85	30,2	1,1	–	78,1
–	3309-BD	XL	1,35	45	100	39,7	1,5	84,4	–
–	3309-BD-TVH	XL	1,335	45	100	39,7	1,5	84,4	–
–	3309-BD-2HRS	XL	1,36	45	100	39,7	1,5	–	87,3
–	3309-BD-2HRS-TVH	XL	1,314	45	100	39,7	1,5	–	87,3
–	3309-BD-2Z	XL	1,361	45	100	39,7	1,5	–	87,3
–	3309-BD-2Z-TVH	XL	1,315	45	100	39,7	1,5	–	87,3
3210-BD	–	XL	0,7	50	90	30,2	1,1	80,1	–
3210-BD-TVH	–	XL	0,672	50	90	30,2	1,1	80,1	–
3210-BD-2HRS	–	XL	0,7	50	90	30,2	1,1	–	82,9
3210-BD-2HRS-TVH	–	XL	0,668	50	90	30,2	1,1	–	82,9
3210-BD-2Z	–	XL	0,695	50	90	30,2	1,1	–	82,9
3210-BD-2Z-TVH	–	XL	0,667	50	90	30,2	1,1	–	82,9
–	3310-BD	XL	1,82	50	110	44,4	2	93,3	–
–	3310-BD-TVH	XL	1,749	50	110	44,4	2	93,3	–
–	3310-BD-2HRS	XL	1,82	50	110	44,4	2	–	96,8
–	3310-BD-2HRS-TVH	XL	1,748	50	110	44,4	2	–	96,8
–	3310-BD-2Z	XL	1,814	50	110	44,4	2	–	96,8
–	3310-BD-2Z-TVH	XL	1,75	50	110	44,4	2	–	96,8

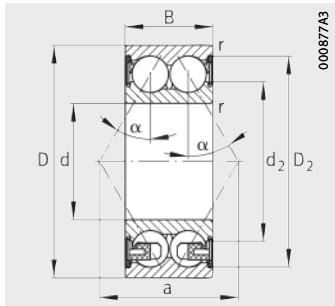

32..-BD-2Z, 33..-BD-2Z
 $\alpha = 30^\circ$

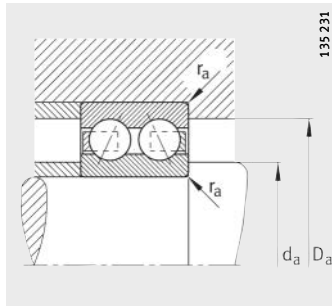

Mounting dimensions

			Mounting dimensions			Basic load ratings		Fatigue limit load C_{ur} N	Limiting speed n_G min^{-1}	Reference speed n_B min^{-1}
d_1 \approx	d_2 \approx	a \approx	d_a min.	D_a max.	r_a max.	dyn. C_r N	stat. C_{0r} N			
59,9	–	50,3	52	78	1	50 000	39 000	2 650	8 300	8 400
59,9	–	50,3	52	78	1	50 000	39 000	2 650	8 300	8 400
–	57,7	50,3	52	78	1	50 000	39 000	2 650	6 300	–
–	57,7	50,3	52	78	1	50 000	39 000	2 650	6 300	–
–	57,7	50,3	52	78	1	50 000	39 000	2 650	6 300	8 400
–	57,7	50,3	52	78	1	50 000	39 000	2 650	6 300	8 400
65,5	–	57,8	54	91	1,5	72 000	54 000	3 600	7 300	6 500
65,5	–	57,8	54	91	1,5	72 000	54 000	3 600	7 300	6 500
–	65,5	57,8	54	91	1,5	72 000	54 000	3 600	5 500	–
–	65,5	57,8	54	91	1,5	72 000	54 000	3 600	5 500	–
–	65,5	57,8	54	91	1,5	72 000	54 000	3 600	5 500	6 500
–	65,5	57,8	54	91	1,5	72 000	54 000	3 600	5 500	6 500
64,9	–	53,2	57	83	1	53 000	44 000	3 000	7 800	7 600
64,9	–	53,2	57	83	1	53 000	44 000	3 000	7 800	7 600
–	62,8	53,2	57	83	1	53 000	44 000	3 000	5 900	–
–	62,8	53,2	57	83	1	53 000	44 000	3 000	5 900	–
–	62,8	53,2	57	83	1	53 000	44 000	3 000	5 900	7 600
–	62,8	53,2	57	83	1	53 000	44 000	3 000	5 900	7 600
71,5	–	64,2	61	99	2	93 000	70 000	4 700	6 500	6 100
71,5	–	64,2	61	99	2	93 000	70 000	4 700	6 500	6 100
–	69	64,2	61	99	2	93 000	70 000	4 700	4 900	–
–	69	64,2	61	99	2	93 000	70 000	4 700	4 900	–
–	69	64,2	61	99	2	93 000	70 000	4 700	4 900	6 100
–	69	64,2	61	99	2	93 000	70 000	4 700	4 900	6 100

Angular contact ball bearings

Double row
Open or sealed

X-life

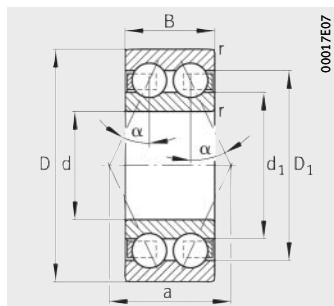

32..-BD, 33..-BD
 $\alpha = 30^\circ$

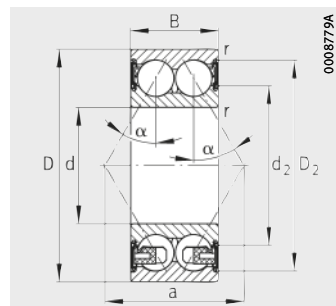

32..-BD-2HRS, 33..-BD-2HRS
 $\alpha = 30^\circ$

Dimension table (continued) · Dimensions in mm

Designation			Mass m ≈ kg	Dimensions					
Series 32	Series 33	X-life		d	D	B	r min.	D ₁ ≈	D ₂ ≈
3211-BD	–	XL	0,94	55	100	33,3	1,5	87,8	–
3211-BD-TVH	–	XL	0,94	55	100	33,3	1,5	87,8	–
3211-BD-2HRS	–	XL	0,98	55	100	33,3	1,5	–	90,8
3211-BD-2HRS-TVH	–	XL	0,933	55	100	33,3	1,5	–	90,8
3211-BD-2Z	–	XL	0,979	55	100	33,3	1,5	–	90,8
3211-BD-2Z-TVH	–	XL	0,93	55	100	33,3	1,5	–	90,8
–	3311-BD	XL	2,35	55	120	49,2	2	103,3	–
–	3311-BD-TVH	XL	2,28	55	120	49,2	2	103,3	–
–	3311-BD-2HRS	XL	2,35	55	120	49,2	2	–	106,8
–	3311-BD-2HRS-TVH	XL	2,264	55	120	49,2	2	–	106,8
–	3311-BD-2Z	XL	2,34	55	120	49,2	2	–	106,8
–	3311-BD-2Z-TVH	XL	2,265	55	120	49,2	2	–	106,8
3212-BD	–	XL	1,31	60	110	36,5	1,5	97	–
3212-BD-TVH	–	XL	1,25	60	110	36,5	1,5	97	–
3212-BD-2HRS	–	XL	1,31	60	110	36,5	1,5	–	100,5
3212-BD-2HRS-TVH	–	XL	1,25	60	110	36,5	1,5	–	100,5
3212-BD-2Z	–	XL	1,301	60	110	36,5	1,5	–	100,5
3212-BD-2Z-TVH	–	XL	1,24	60	110	36,5	1,5	–	100,5
3213-BD	–	XL	1,67	65	120	38,1	1,5	106,6	–
3213-BD-TVH	–	XL	1,604	65	120	38,1	1,5	106,6	–
3213-BD-2HRS	–	XL	1,67	65	120	38,1	1,5	–	110,1
3213-BD-2HRS-TVH	–	XL	1,6	65	120	38,1	1,5	–	110,1
3213-BD-2Z	–	XL	1,667	65	120	38,1	1,5	–	110,1
3213-BD-2Z-TVH	–	XL	1,602	65	120	38,1	1,5	–	110,1

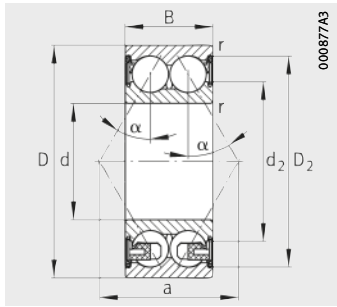

32..-BD-2Z, 33..-BD-2Z
 $\alpha = 30^\circ$

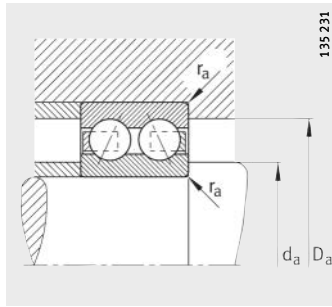

Mounting dimensions

			Mounting dimensions			Basic load ratings		Fatigue limit load C_{ur} N	Limiting speed n_G min^{-1}	Reference speed n_B min^{-1}
d_1 \approx	d_2 \approx	a \approx	d_a min.	D_a max.	r_a max.	dyn. C_r N	stat. C_{0r} N			
71,6	–	58,5	64	91	1,5	61 000	51 000	3 450	7 100	7 200
71,6	–	58,5	64	91	1,5	61 000	51 000	3 450	7 100	7 200
–	69,2	58,5	64	91	1,5	61 000	51 000	3 450	5 300	–
–	69,2	58,5	64	91	1,5	61 000	51 000	3 450	5 300	–
–	69,2	58,5	64	91	1,5	61 000	51 000	3 450	5 300	7 200
–	69,2	58,5	64	91	1,5	61 000	51 000	3 450	5 300	7 200
78,8	–	71,4	66	109	2	116 000	88 000	6 000	5 800	5 800
78,8	–	71,4	66	109	2	116 000	88 000	6 000	5 800	5 800
–	76,4	71,4	66	109	2	116 000	88 000	6 000	4 350	–
–	76,4	71,4	66	109	2	116 000	88 000	6 000	4 350	–
–	76,4	71,4	66	109	2	116 000	88 000	6 000	4 350	5 800
–	76,4	71,4	66	109	2	116 000	88 000	6 000	4 350	5 800
79	–	64,7	69	101	1,5	75 000	64 000	4 300	6 300	6 700
79	–	64,7	69	101	1,5	75 000	64 000	4 300	6 300	6 700
–	76,6	64,7	69	101	1,5	75 000	64 000	4 300	4 750	–
–	76,6	64,7	69	101	1,5	75 000	64 000	4 300	4 750	–
–	76,6	64,7	69	101	1,5	75 000	64 000	4 300	4 750	6 700
–	76,6	64,7	69	101	1,5	75 000	64 000	4 300	4 750	6 700
87,7	–	70,7	74	111	1,5	86 000	77 000	5 200	5 700	6 100
87,7	–	70,7	74	111	1,5	86 000	77 000	5 200	5 700	6 100
–	85,3	70,7	74	111	1,5	86 000	77 000	5 200	4 250	–
–	85,3	70,7	74	111	1,5	86 000	77 000	5 200	4 300	–
–	85,3	70,7	74	111	1,5	86 000	77 000	5 200	4 250	6 100
–	85,3	70,7	74	111	1,5	86 000	77 000	5 200	4 300	6 100

Schaeffler Technologies AG & Co. KG

Georg-Schäfer-Straße 30
97421 Schweinfurt
Germany
Internet www.fag.com
E-mail faginfo@schaeffler.com

In Germany:

Phone 0180 5003872
Fax 0180 5003873

From other countries:

Phone +49 9721 91-0
Fax +49 9721 91-3435

Every care has been taken to ensure the correctness of the information contained in this publication but no liability can be accepted for any errors or omissions. We reserve the right to make technical changes.

© Schaeffler Technologies AG & Co. KG
Issued: 2016, November

This publication or parts thereof may not be reproduced without our permission.

TPI 213 GB-D